

## Drawing Index

Name	Doc.No	Document Description
<a href="#">2001979.018.pdf</a>	2001979.018	WATER RETICULATION STANDARD STEEL PIPE SPIGOT AND SOCKET JOINTS DESIGN DIMENSIONS
<a href="#">2001979.019D.pdf</a>	2001979.019	WATER RETICULATION STANDARD CLS PIPE JOINTS WELDING AND TESTING DETAILS
<a href="#">2001979.021.pdf</a>	2001979.021	WATER RETICULATION STANDARD BOLT TIGHTENING SEQUENCE 32HOLE FLANGE TO 48HOLE FLANGE
<a href="#">2001979.022.pdf</a>	2001979.022	WATER RETICULATION STANDARD BOLT TIGHTENING SEQUENCE 8HOLE TO 28HOLE FLANGE
<a href="#">2001979.029E.pdf</a>	2001979.029	WATER RETICULATION STANDARD CLS PIPE TESTING STOP ENDS TYPE NO1 TO TYPE NO4 GENERAL ARRANGEMENT AND DETAILS
<a href="#">2001979.031.pdf</a>	2001979.031	WATER RETICULATION STANDARD PIPELINE TAPPING PORTS DETAILS FOR CAST IRON AND STEEL PIPES
<a href="#">2001979.032.pdf</a>	2001979.032	WATER RETICULATION STANDARD MANHOLE SOFFIT PLATE FOR FLOW STREAMLINING DETAILS AND ELEVATION ON SOFFIT PLATE
<a href="#">2001979.060C.pdf</a>	2001979.060	WATER RETICULATION STANDARD CLS PIPELINE BENDS AND TAPERS SET OUT DIMENSIONS
<a href="#">2001979.074.pdf</a>	2001979.074	WATER RETICULATION STANDARD ACCESS MANHOLE BOLT DOWN TYPE

<a href="#">2001979.075B.pdf</a>	2001979.075	WATER SUPPLY STANDARD ACCESS MANHOLE WELD DOWN TYPE FOR PIPES GREATER THAN 700MM DIA
<a href="#">2001979.092C.pdf</a>	2001979.092	WATER RETICULATION STANDARD CLS AND PLASTIC PIPE IN TRENCH TYPICAL BEDDING BACKFILL AND REINSTATEMENT DETAIL

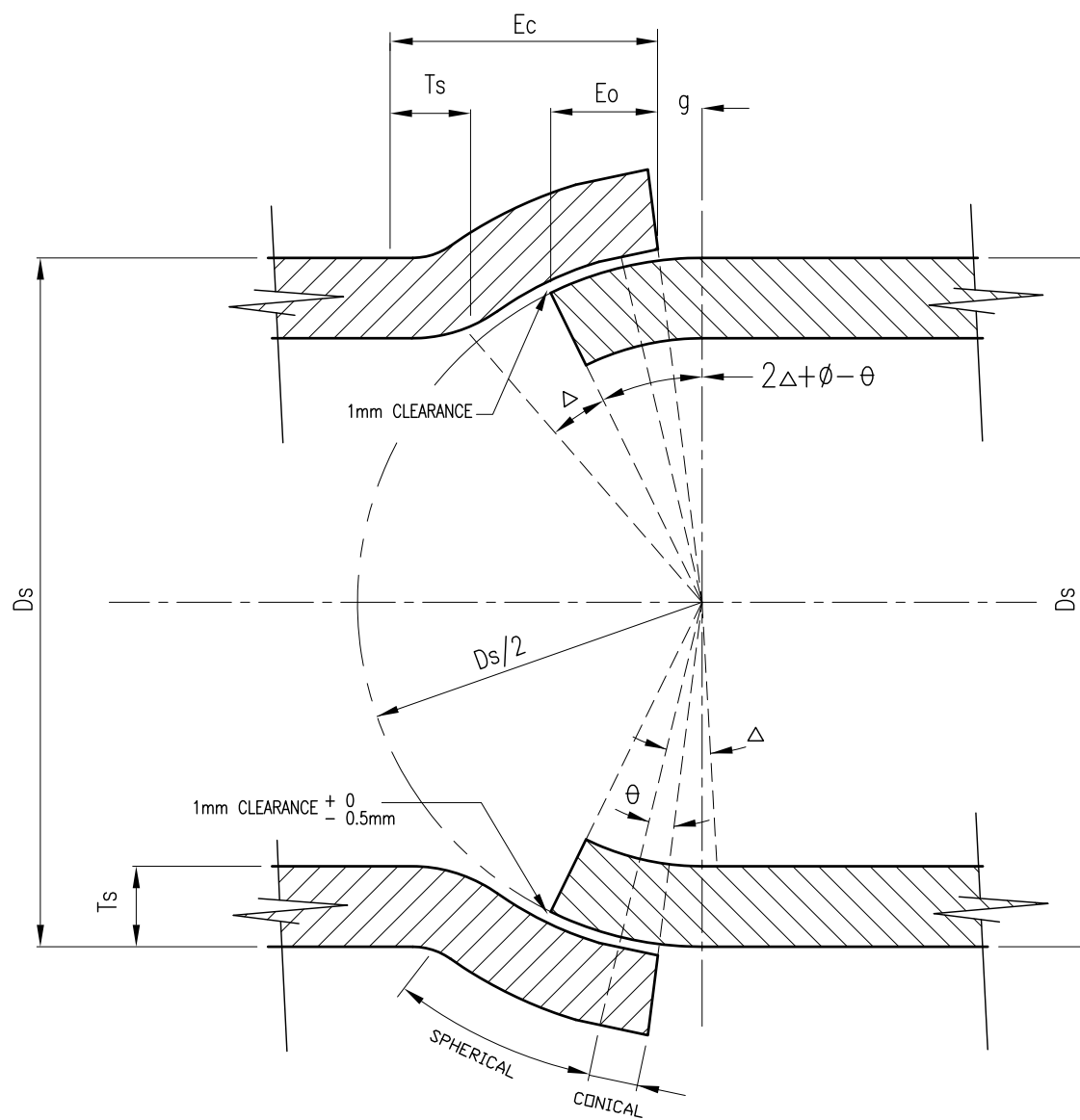

SECTION THROUGH STRAIGHT LINE JOINT

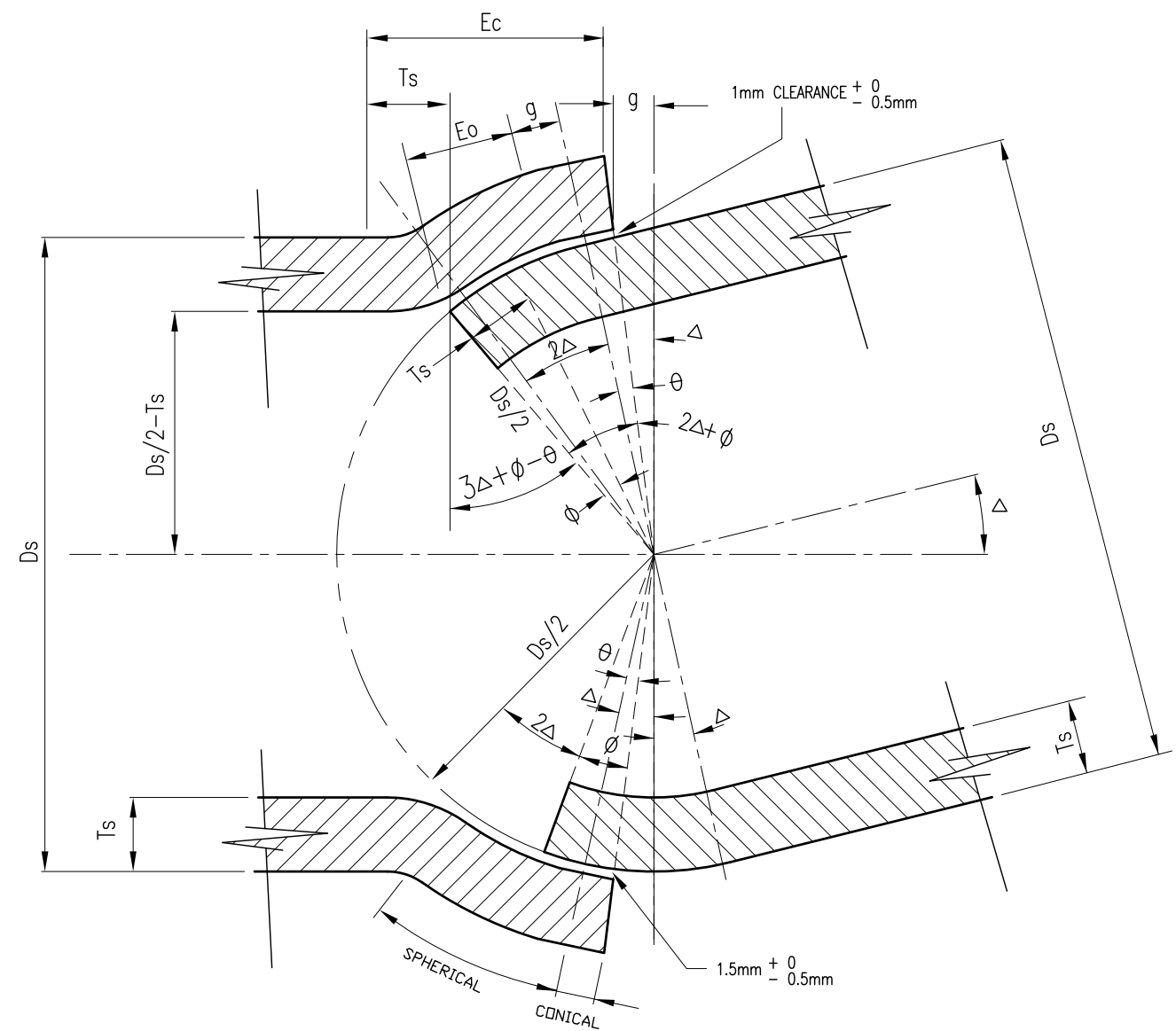

SECTION THROUGH JOINT DEFLECTED TO MAXIMUM

KEY	
$E_o = \pi/180 \times D_s/2 [(2\Delta + \phi - \theta) - (\Delta - \theta)]$	$D_s = \text{O.D. OF STEEL PIPE}$
$E_c = 2 \times E_o + T_s$	$T_s = \text{THICKNESS OF STEEL PIPE}$
$\Delta = 1/3 [\cos^{-1}(1 - 2T_s/D_s) - \phi + \theta]$	$E_c = \text{SET BACK OF CONCRETE LINING AND ENAMEL COATING}$
$\phi = 180/\pi \times 2T_s/D_s$	$E_o = \text{LENGTH OF STRAIGHT LINE ENTRY}$
$\theta = 2 \times \phi$	$\Delta = \text{MAXIMUM DEFLECTION ANGLE}$
$g = D_s/2 \sin(\Delta - \theta)$	$\phi = \text{ANGLE SUBTENDED BY AN ARC OF } T_s \text{ AT RADIUS } D_s/2$
	$\theta = \text{ANGLE SUBTENDED BY THE CONICAL SECTION OF SOCKET AT THE CENTRE OF THE SPHERICAL JOINT}$

**NOTE**  
PIPE COATING AND LINING OMITTED FOR CLARITY

ISSUE	DATE	AMENDMENT	BY	APPD.	DATE
A	06:15	TABLE WITH FORMULA'S AMENDED	LC.	JD.	

DESIGNED	DES. CHECKED	DRAWN	DWG. CHECKED	PROJECT LEADER
E. SANLEN		P. ROURKE		

**COPYRIGHT**  
This drawing, the design and concept, remain the exclusive property of Watercare Services Limited and may not be used without approval. Copyright reserved.



**WATERCARE SERVICES WATER RETICULATION**  
**STANDARD PIPELINES**  
**STEEL PIPE SPIGOT AND SOCKET JOINTS**

CAD FILE	DATE	ORIGINAL SCALE	CONTRACT No.	DRAWING No.	ISSUE
2001979.018A	09-06-15	A1		2001979 .018	A

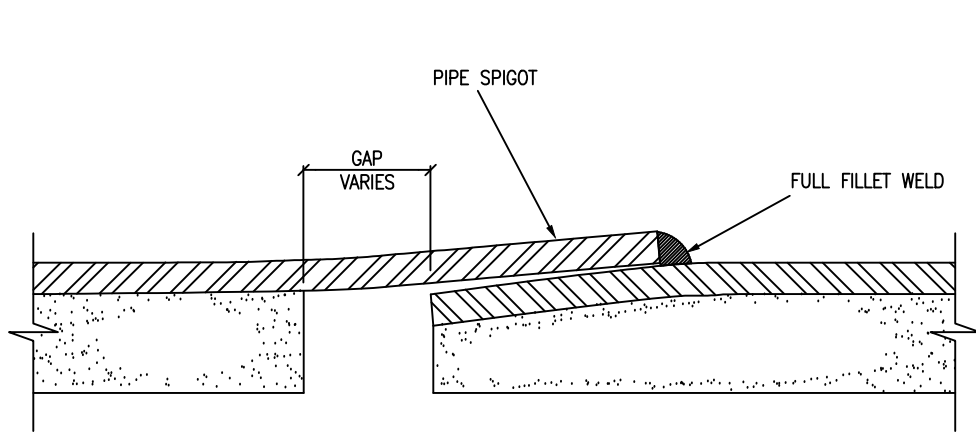

TYPICAL SECTION THRU SOCKET & SPIGOT JOINT FOR PIPES  $\leq$  NOM. 630 DIA.

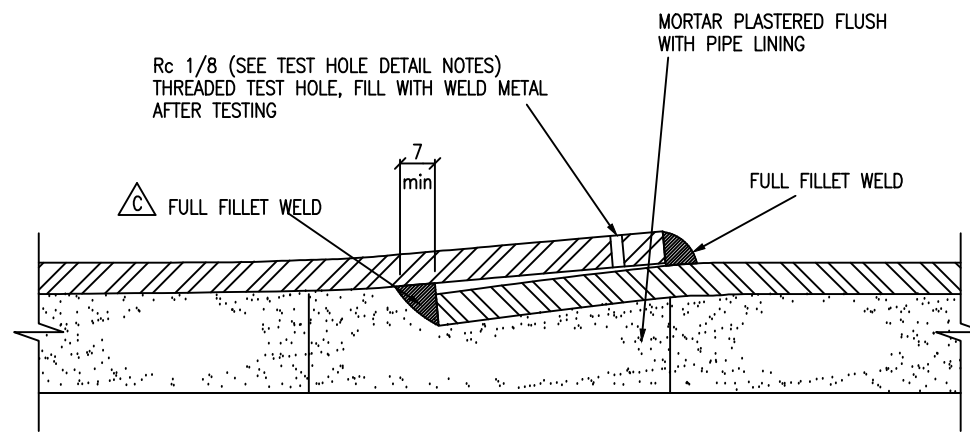

TYPICAL SECTION THRU SOCKET & SPIGOT JOINT FOR PIPES  $\geq$  NOM. 700 DIA.

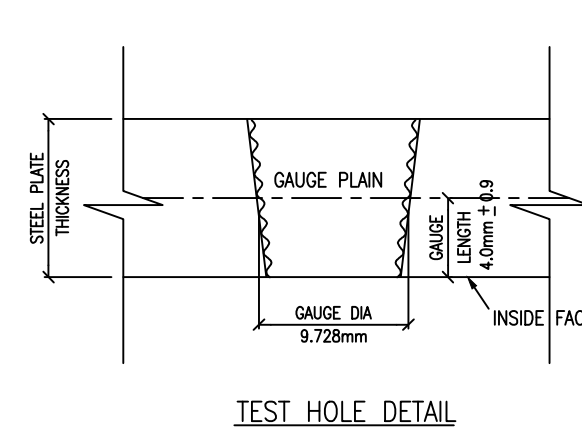

TEST HOLE DETAIL

WELDING BAND DETAILS.	
NOM. PIPE SIZE (mm)	WELDING BAND SIZE (mm)
100 TO 390 DIA.	100x6 (Wxt)
470 TO 630 DIA.	150x6 (Wxt)
700 TO 1300 DIA.	150x10 (Wxt)
OVER 1300 DIA.	200x12 (Wxt)

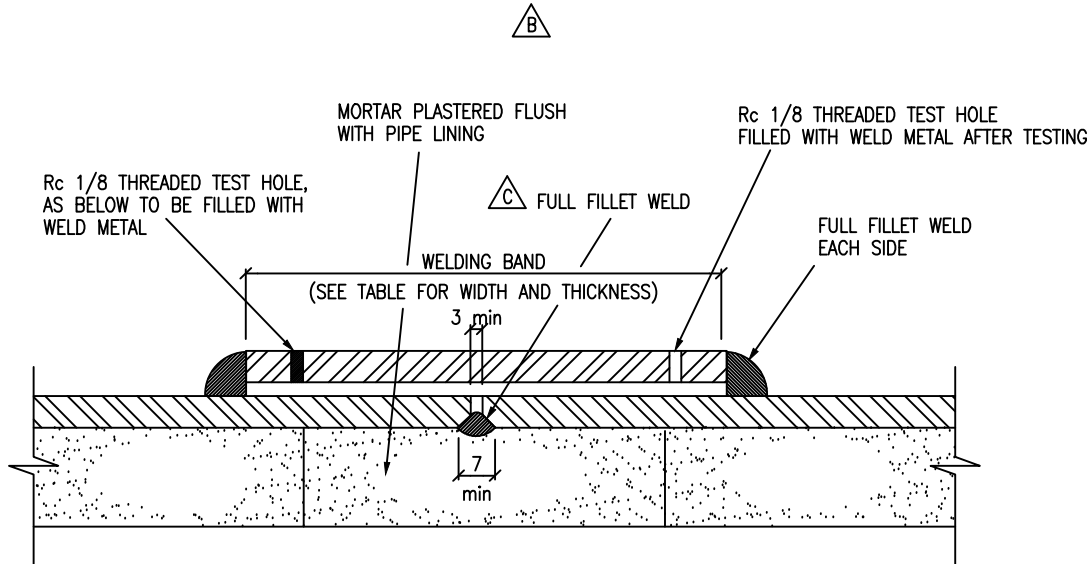

TYPICAL SECTION THRU JOINT ON PIPES  $\geq$  700 DIAMETER WITH WELDING BAND WHERE ENDS FIT NEATLY

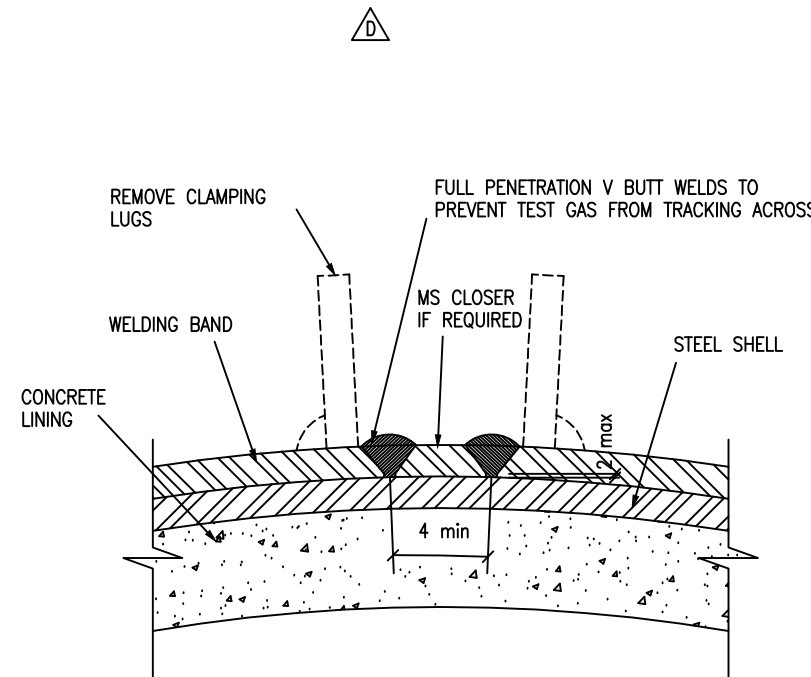

WELDING BAND CLOSING DETAIL

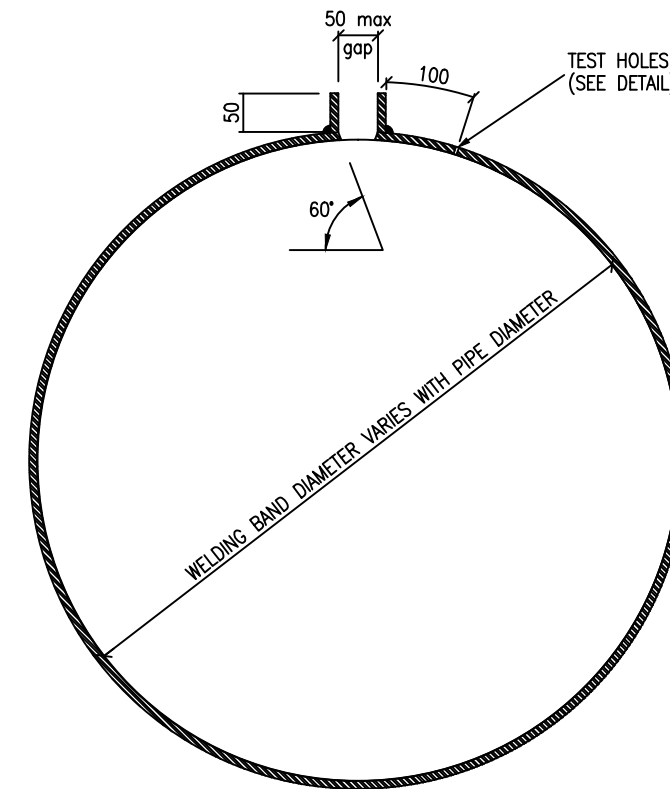

SEE TABLE FOR WIDTH (W)

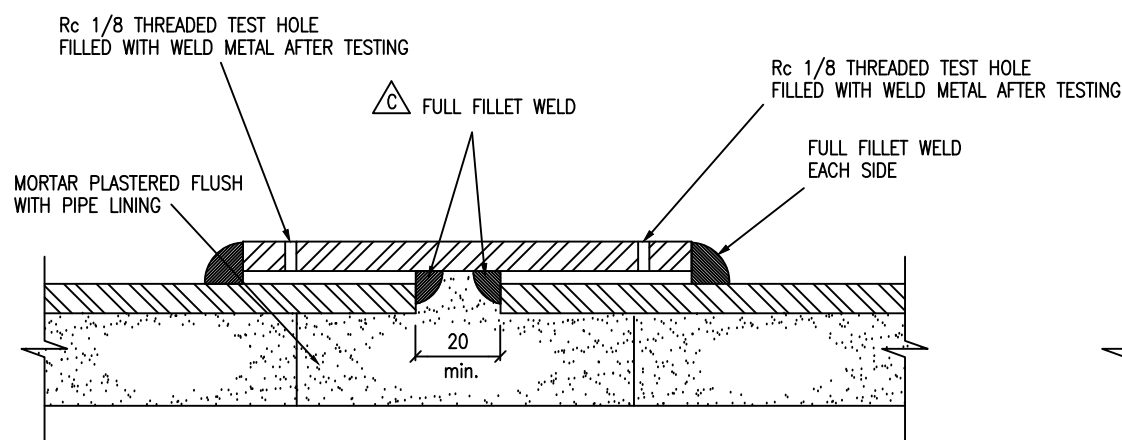
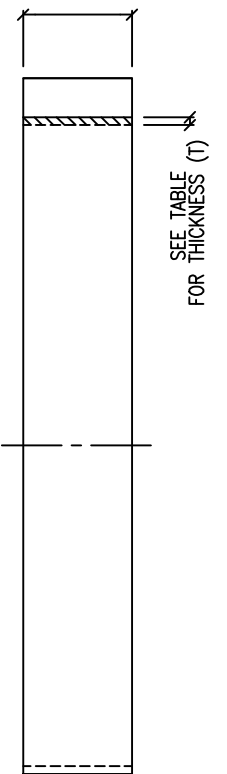

TYPICAL SECTION THRU PIPE JOINT WITH WELDING BAND ON PIPES  $\geq$  NOM. 700 DIA.

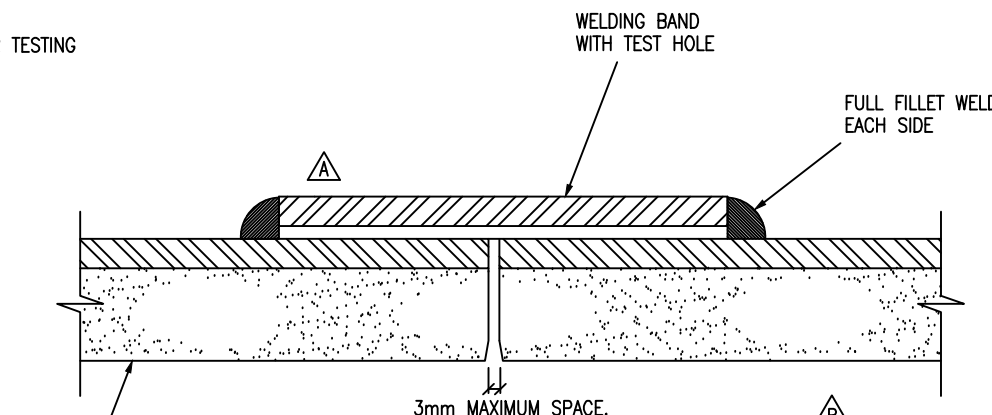

TYPICAL SECTION THRU PIPE JOINT ON PIPES  $\leq$  NOM. 630 DIA. WITH WELDING BAND WHERE ENDS FIT NEATLY

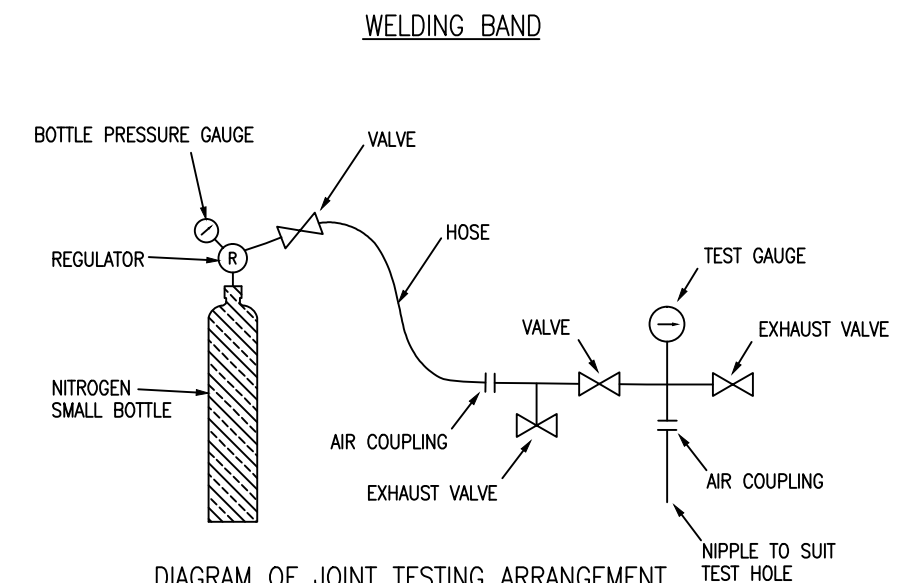

DIAGRAM OF JOINT TESTING ARRANGEMENT

ISSUE	DATE	AMENDMENT	BY	APPD.	DESIGNED	T.C	8-04
D	02-15	SECTION HEADINGS AMENDED	I.M.	B.P.	DRAWN	P.B.	8-04
C	03-13	WELDING DETAILS AMENDED	I.M.	B.P.	DWG. CHECKED		
B	8/04	JOINT DETAILS AMENDED	L.A.C.	T.A.C.	PROJECT LEADER		
A	4/02	PIPE SIZES AND WELDING BAND AMENDED	I.M.M.	M.R.	AD APPROVED	R.P.	8-04

S. CUNIS	OPERATIONS
T. MUNRO	INFRASTRUCTURE

**waterCare**  
services limited

WATERCARE STANDARD PIPELINES  
C.L.S. PIPE WELDING AND TESTING DETAILS

CAD FILE 2001979.019D	DATE 26-02-15
ORIGINAL SCALE A1	CONTRACT No.
N.T.S.	
DRAWING No.	ISSUE
2001979 .019	D

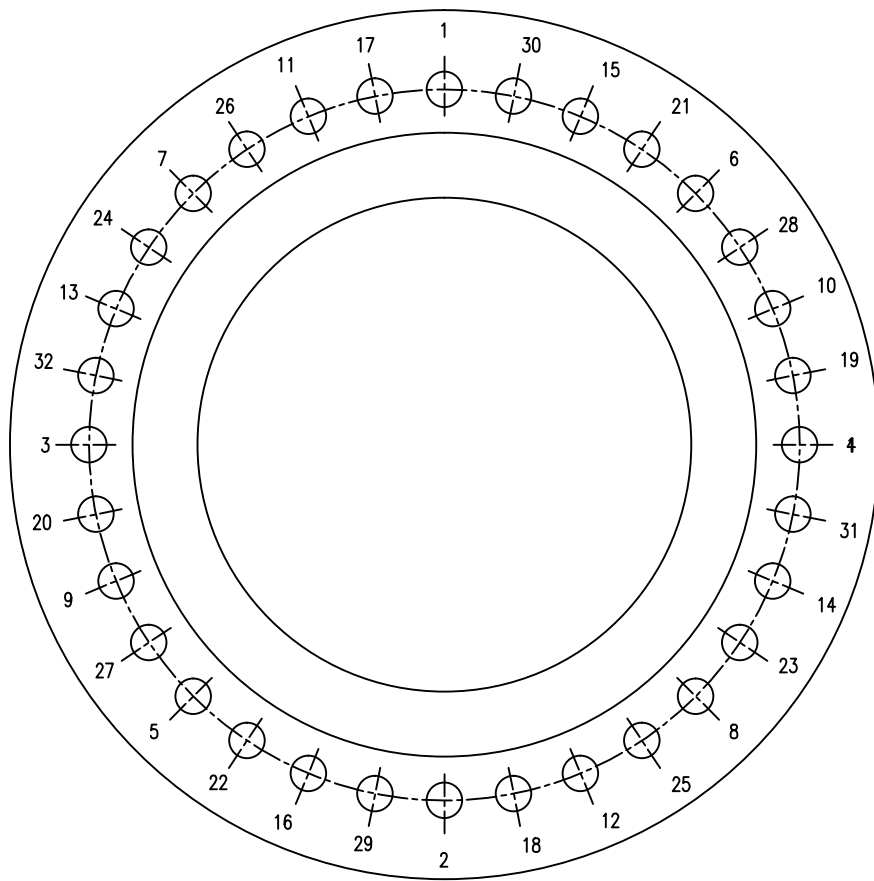

32 BOLT FLANGE

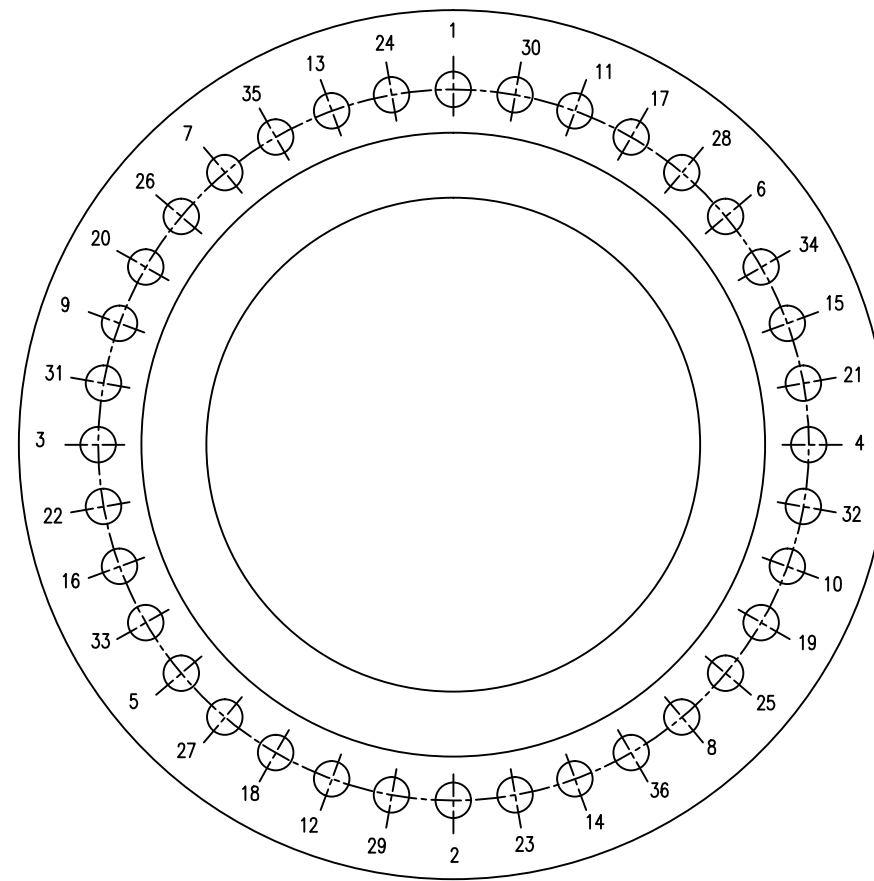

36 BOLT FLANGE

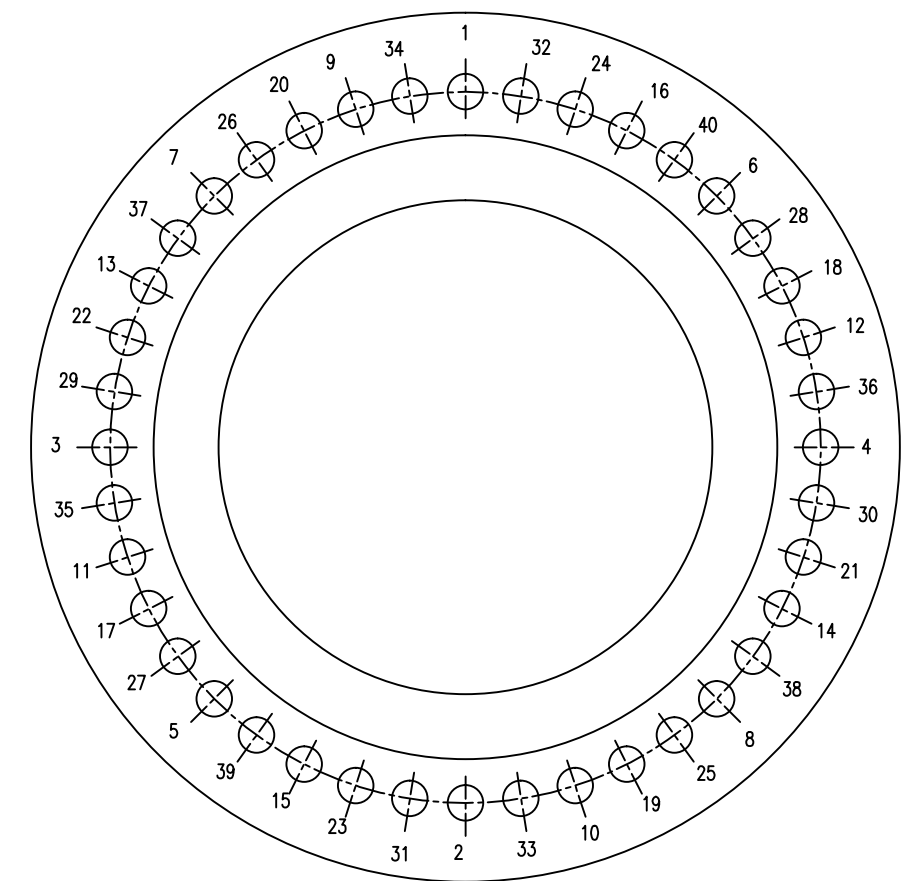

40 BOLT FLANGE

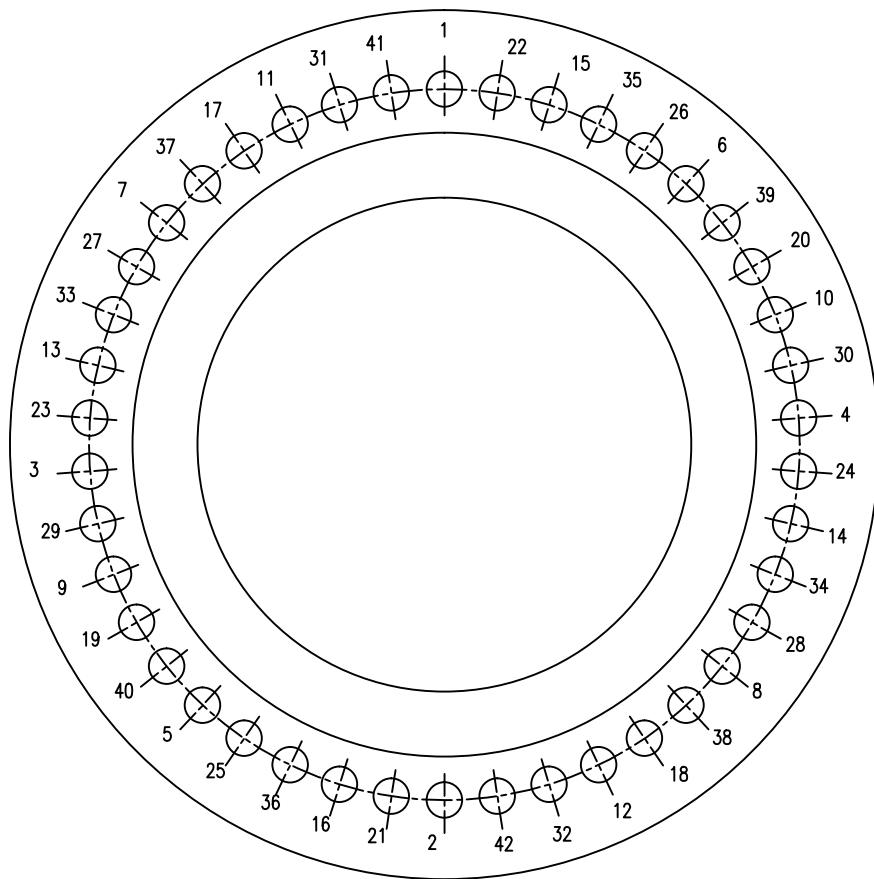

42 BOLT FLANGE

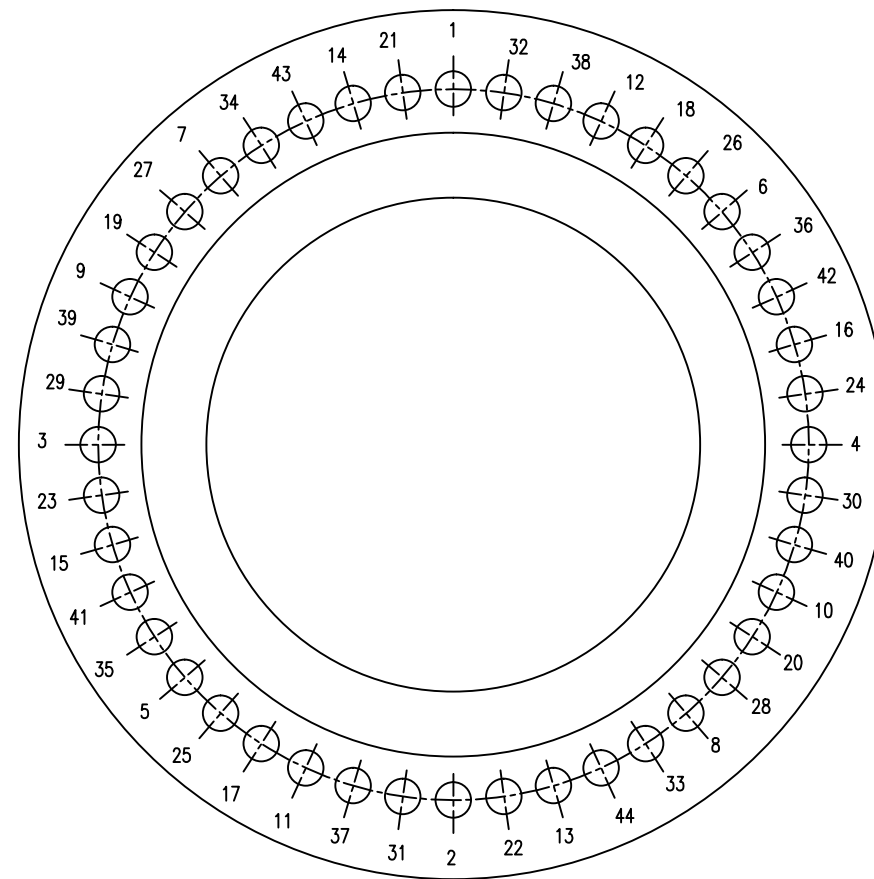

44 BOLT FLANGE

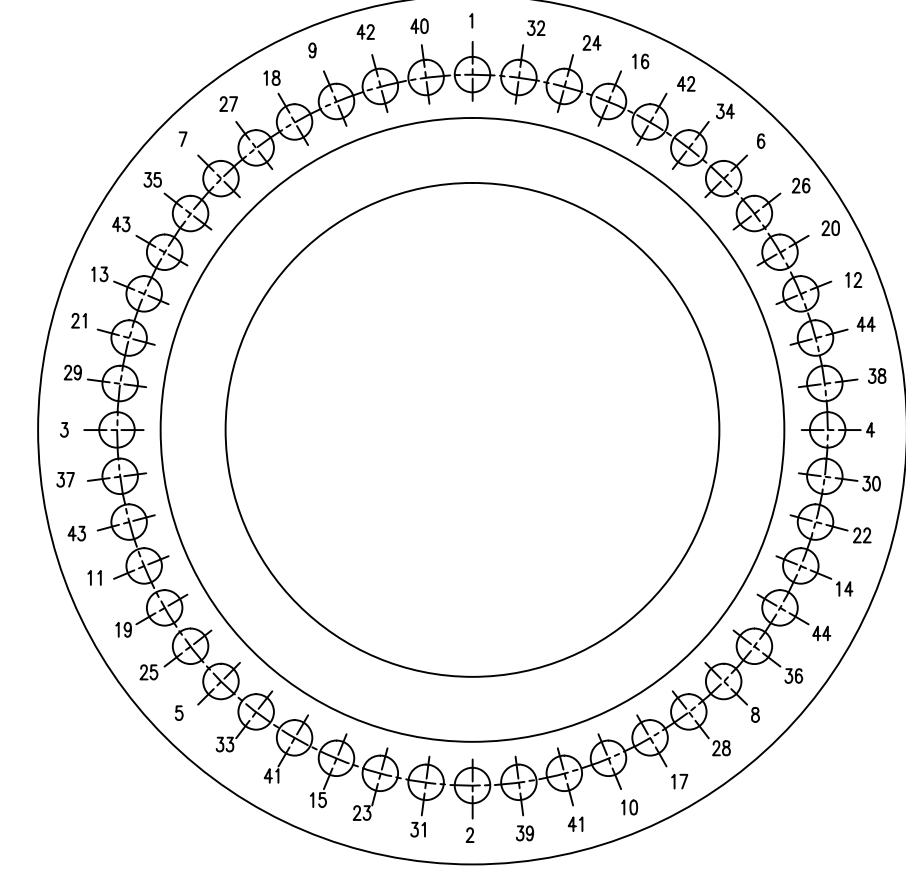

48 BOLT FLANGE

DESIGNED	S.CUNIS				
DES. CHECKED					
DRAWN	P.ROURKE	10:98			
DWG. CHECKED					
PROJECT LEADER					
ISSUE	DATE	AMENDMENT	BY	APPD.	BY
					DATE

OPERATIONS MANAGER  
WATER

PLANNING MANAGER  
WATER



WATERCARE SERVICES WATER RETICULATION  
STANDARD BOLT TIGHTENING SEQUENCE  
32 HOLE FLANGE TO 48 HOLE FLANGE

CAD FILE 2001979.021	DATE 29:08:01
ORIGINAL SCALE A1	CONTRACT No.
N.T.S.	
DRAWING No. 2001979	ISSUE .021

COPYRIGHT  
This drawing, the design and concept, remain the exclusive property of Watercare Services Limited and may not be used without approval  
Copyright reserved.

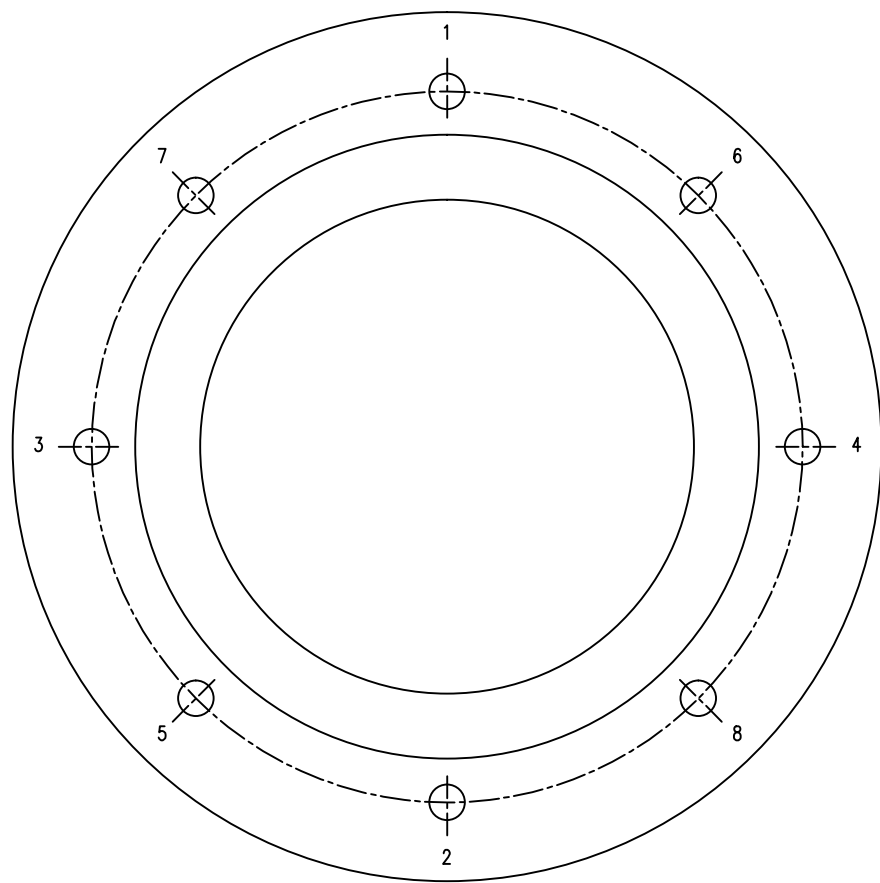

8 BOLT FLANGE

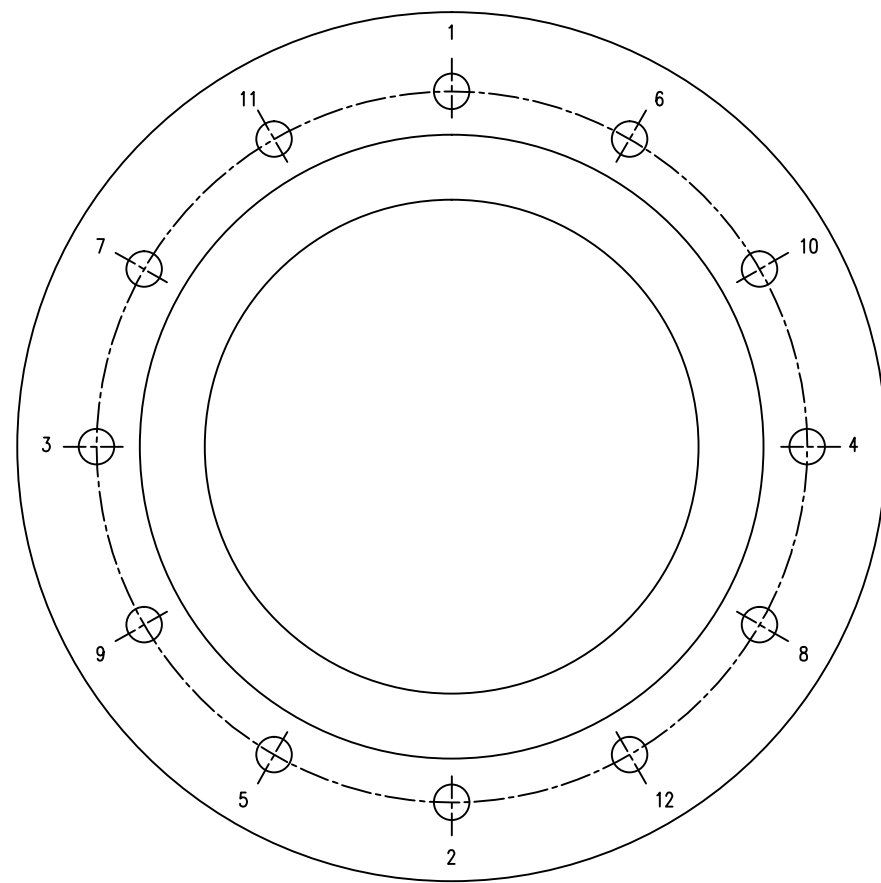

12 BOLT FLANGE

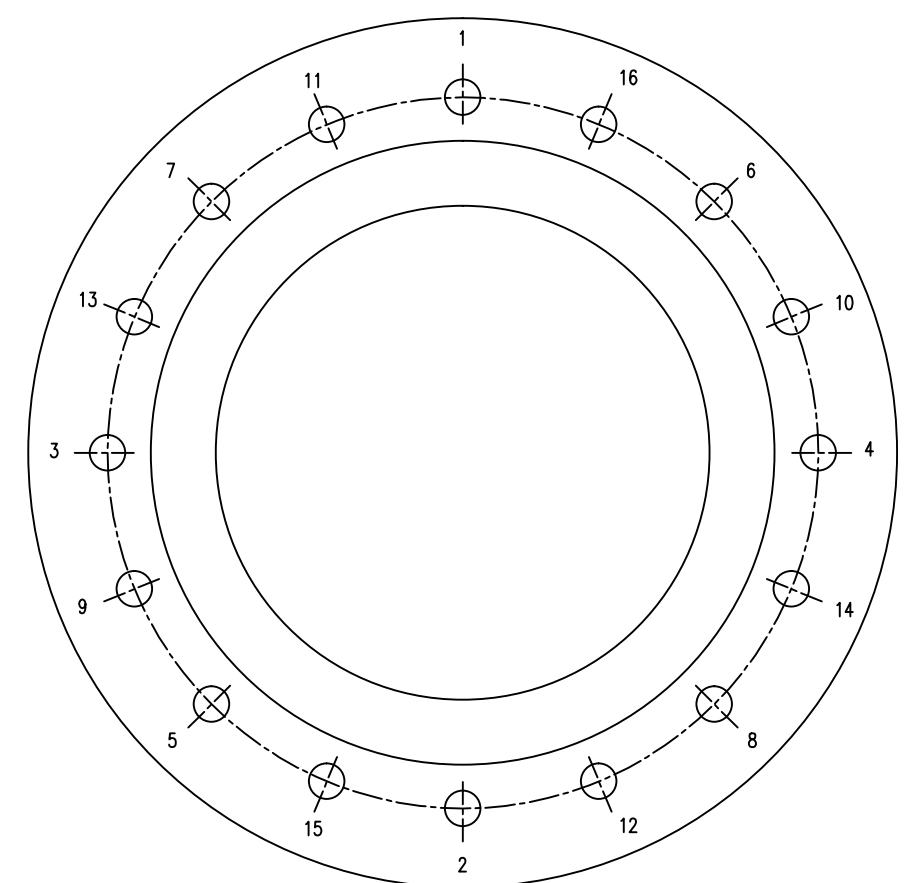

16 BOLT FLANGE

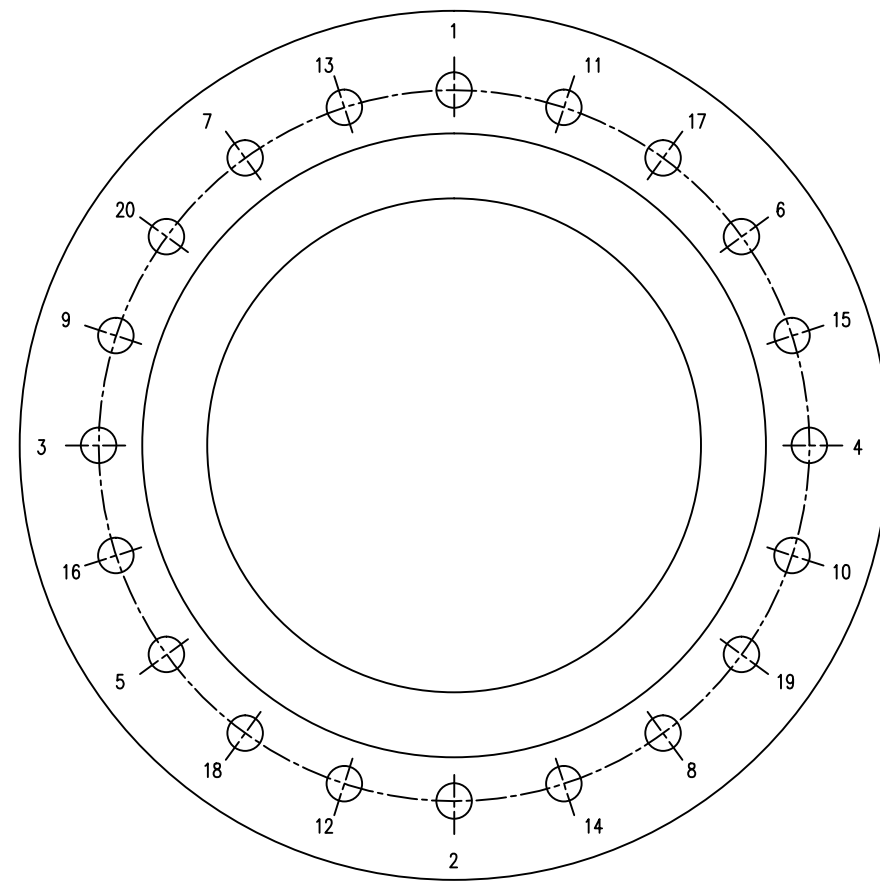

20 BOLT FLANGE

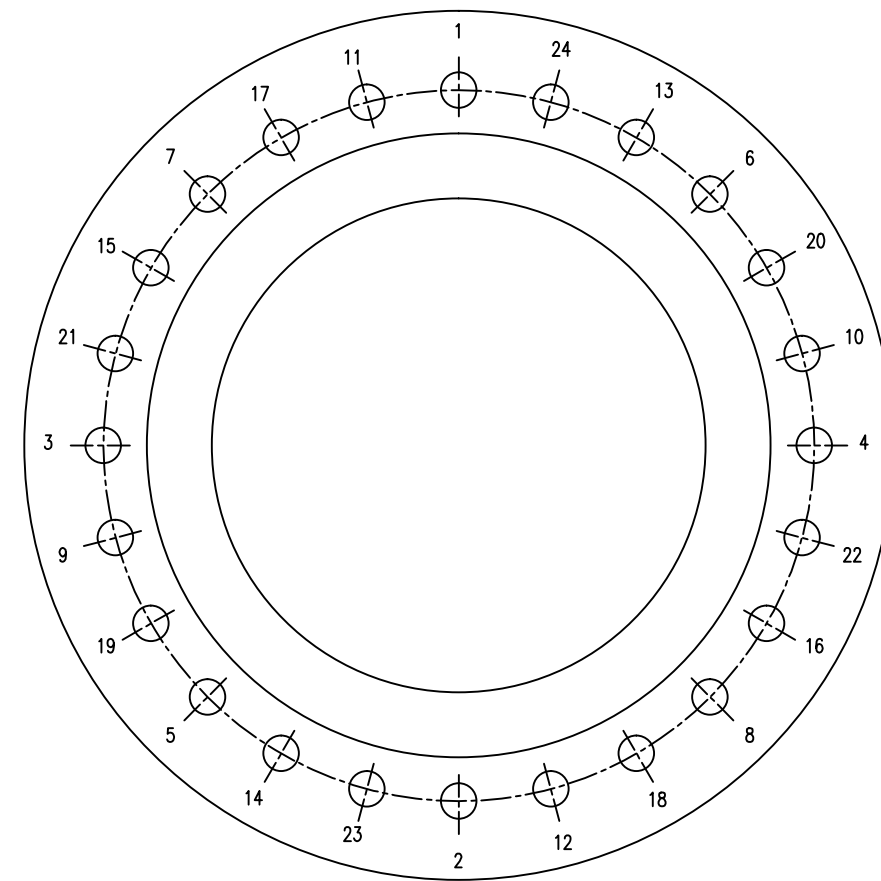

24 BOLT FLANGE

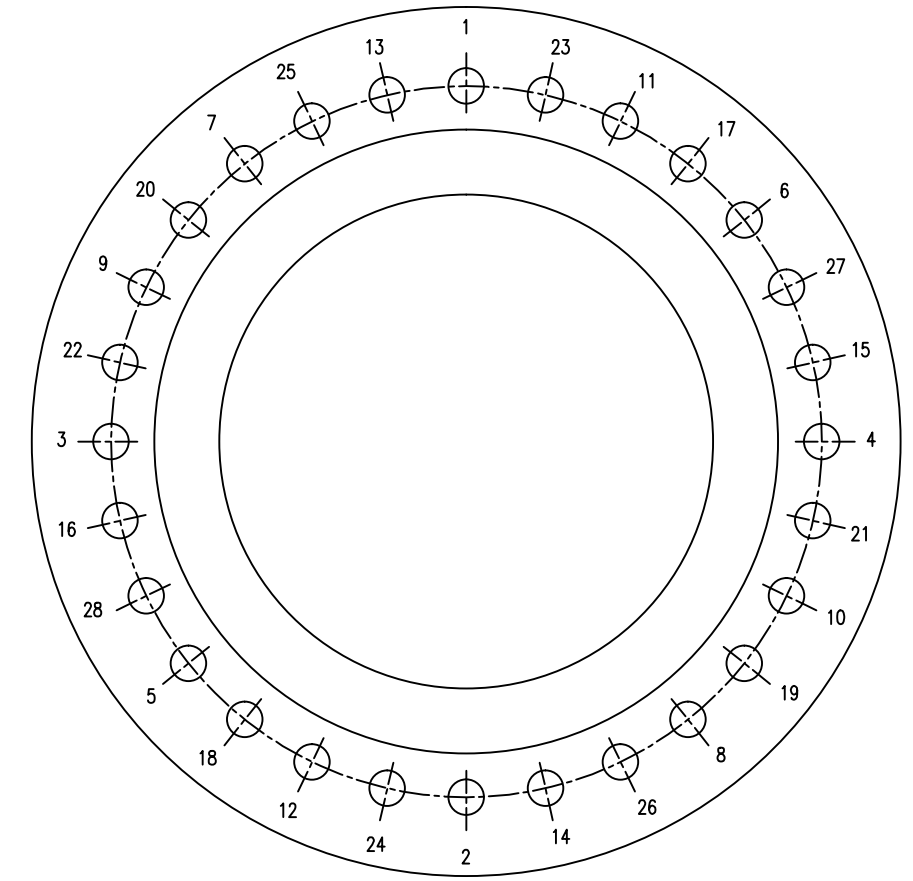

28 BOLT FLANGE

DESIGNED	S.CUNIS				
DES. CHECKED					
DRAWN	P.ROURKE	10:98			
DWG. CHECKED					
PROJECT LEADER					
ISSUE	DATE	AMENDMENT	BY	APPD.	BY

OPERATIONS MANAGER WATER	
PLANNING MANAGER WATER	



WATERCARE SERVICES WATER RETICULATION  
 STANDARD BOLT TIGHTENING SEQUENCE  
 8 HOLE FLANGE TO 28 HOLE FLANGE

CAD FILE 2001979.022	DATE 29:08:01
ORIGINAL SCALE A1	CONTRACT No.
N.T.S.	
DRAWING No. 2001979	ISSUE .022

COPYRIGHT  
 This drawing, the design and concept, remain the exclusive property of Watercare Services Limited and may not be used without approval  
 Copyright reserved.

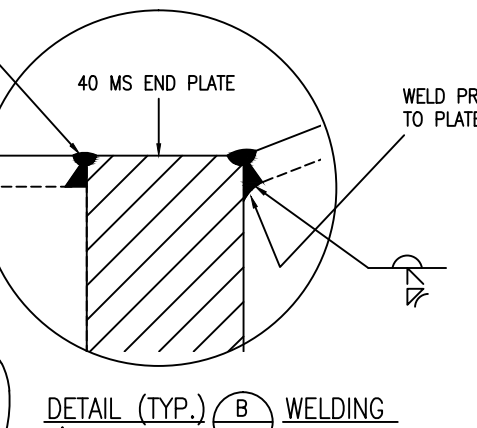
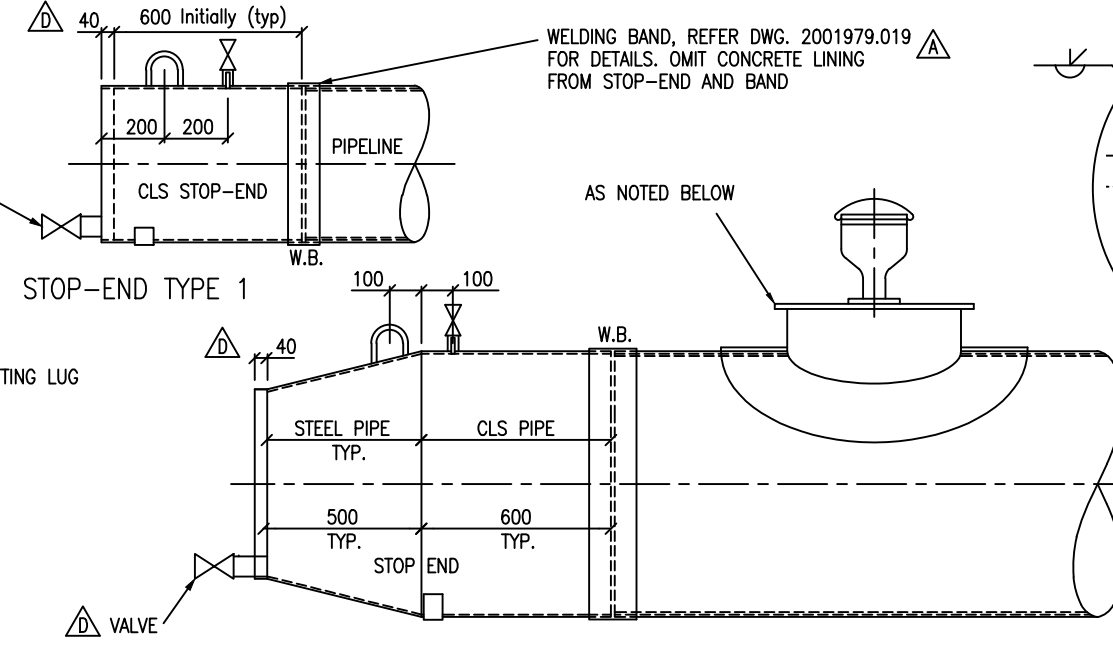
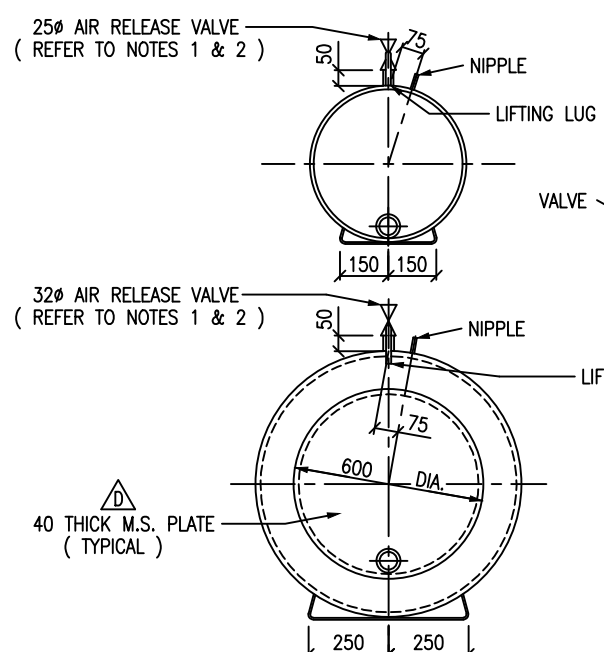

USAGE TABLE	
NOM. CLS PIPE DIA. (mm)	TOTAL WEIGHT OF STOP-END (kg)
310	45
390	67
470	80
550	93
630	163
700	179
810	237
910	262
1070	452
1220	506
1300	522
1500	751
1700	890
1900	955

NOTE: WEIGHT OF STOP-END INCLUDES PIPE COMPONENTS, END PLATE & STIFFENERS IF REQUIRED

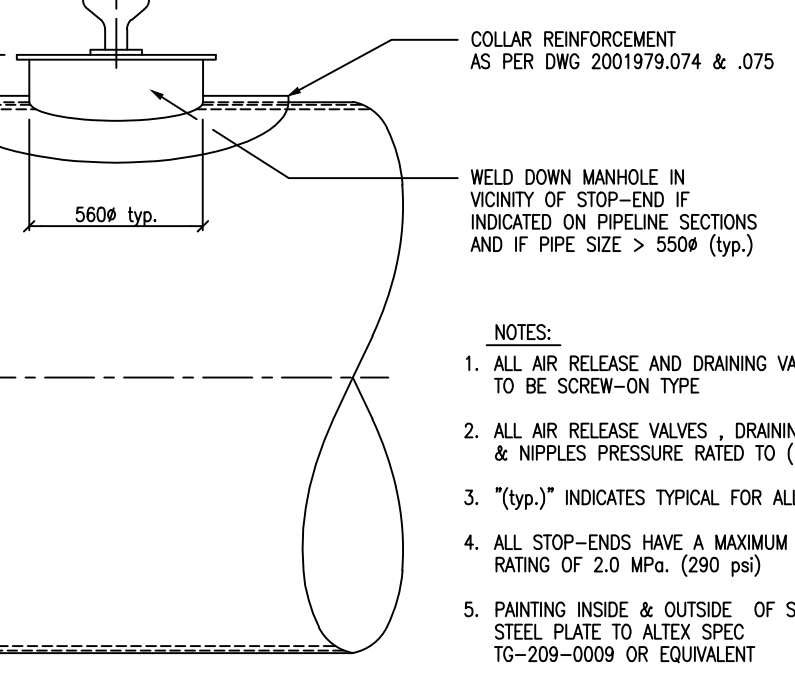
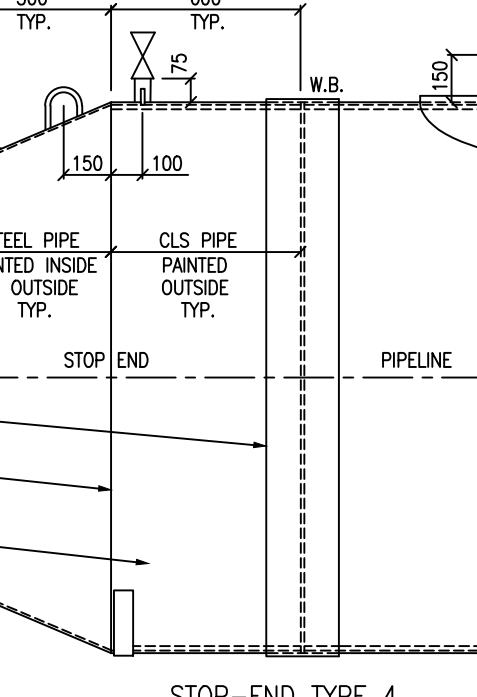
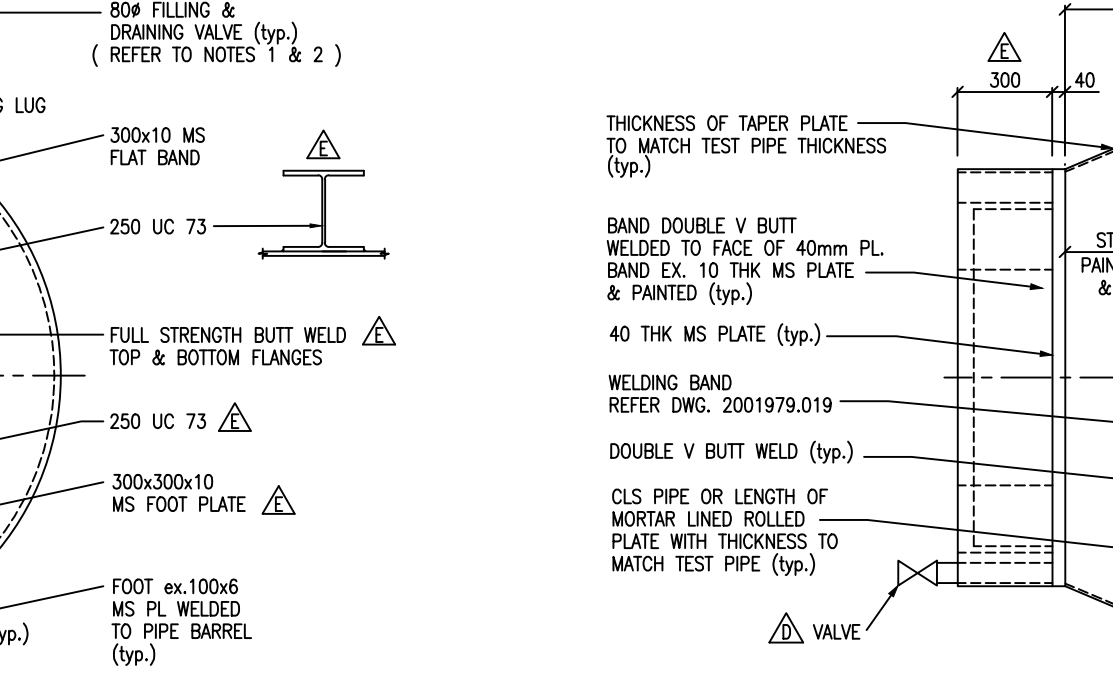
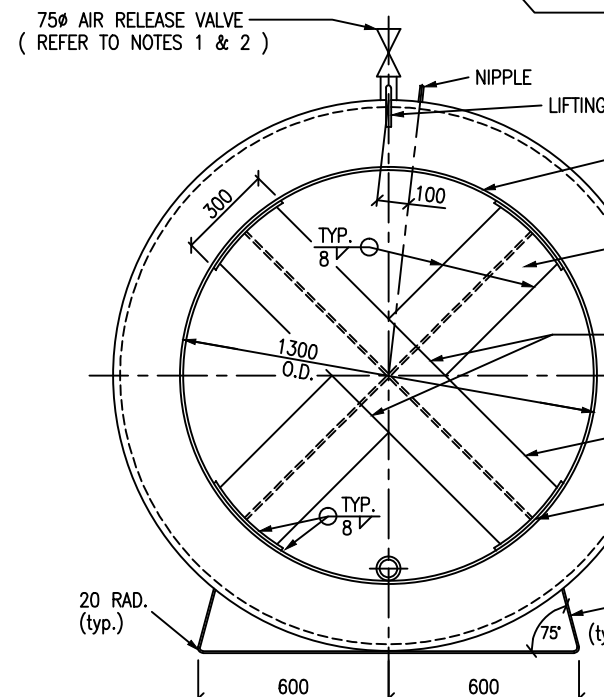
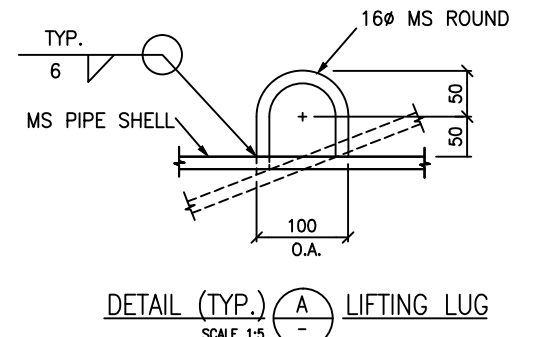
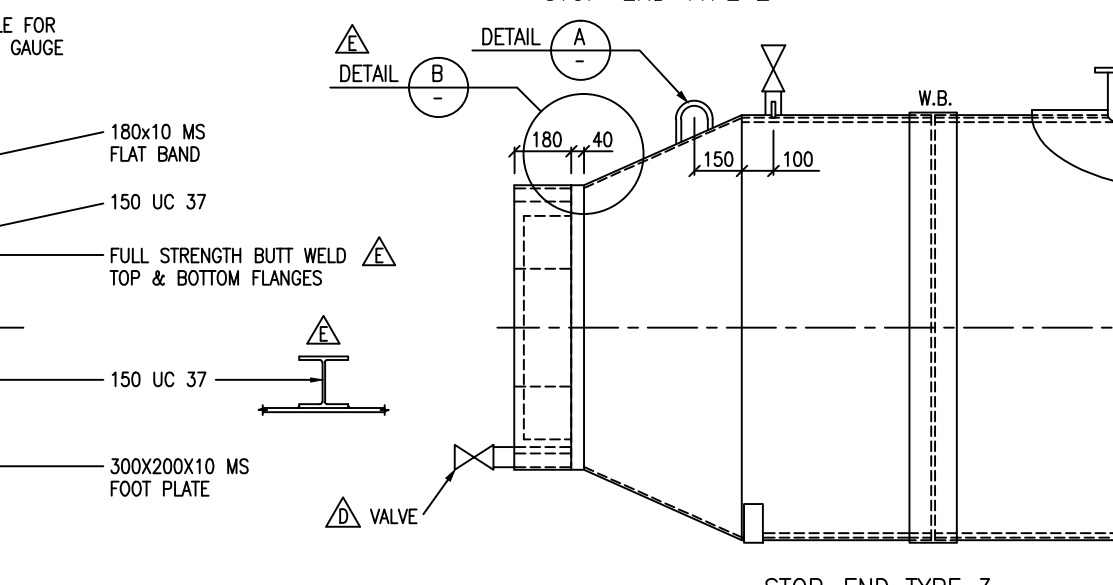
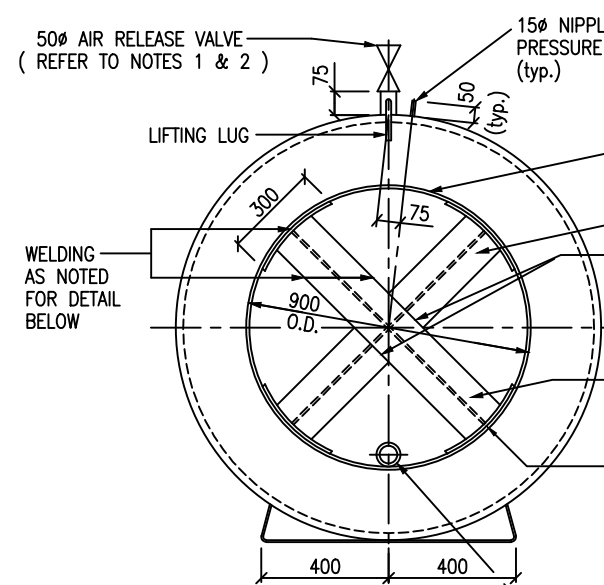

- NOTES:
- ALL AIR RELEASE AND DRAINING VALVES TO BE SCREW-ON TYPE
  - ALL AIR RELEASE VALVES, DRAINING VALVES & NIPPLES PRESSURE RATED TO ( 2.0 MPA )
  - "(typ.)" INDICATES TYPICAL FOR ALL STOP-ENDS
  - ALL STOP-ENDS HAVE A MAXIMUM PRESSURE RATING OF 2.0 MPa. (290 psi)
  - PAINTING INSIDE & OUTSIDE OF STOP-END STEEL PLATE TO ALTEX SPEC TG-209-0009 OR EQUIVALENT

L:\---\EGCAD\2011\STANDARD WATER DWGS\2001979.029E.DWG

ISSUE	DATE	AMENDMENT	BY	APPD.	DESIGNED	T.C.	DATE
E	3:11	BRACING SIZE INCREASED FOR STOP ENDS 3 & 4	L.C.	T.C.	DES. CHECKED	C.K.	03:11
D	2:11	MINOR AMENDMENTS	L.C.	T.C.	DRAWN	P.B. & L.C.	03:11
C	7:09	WELDING DETAIL ADDED AND DETAILS AMENDED	I.M.	T.C.	DWG. CHECKED	I.M.	03:11
B	12:07	GENERAL REVISION & NOTES ADDED	L.C.	T.C.	PROJECT LEADER	T.C.	03:11
A	05:03	CROSS REFERENCED PLAN UPDATED	I.M.	J.P.			

DESIGNED	T.C.	DATE
T. HAWKE		03:11
OPERATIONS		
A. STEWART		
ASSET MANAGEMENT		

COPYRIGHT  
This drawing, the design and concept, remain the exclusive property of Watercare Services Limited and may not be used without approval  
Copyright reserved.

**waterCare**  
services limited

WATER RETICULATION STANDARD  
C.L.S. PIPE TESTING  
GENERAL ARRANGEMENT AND DETAILS OF STOP ENDS TYPE 1 TO TYPE 4

CAD FILE	DATE
2001979.029E	24-3-11
ORIGINAL SCALE	CONTRACT No.
A1	
1:12.5	
DRAWING No.	ISSUE
2001979 .029	E

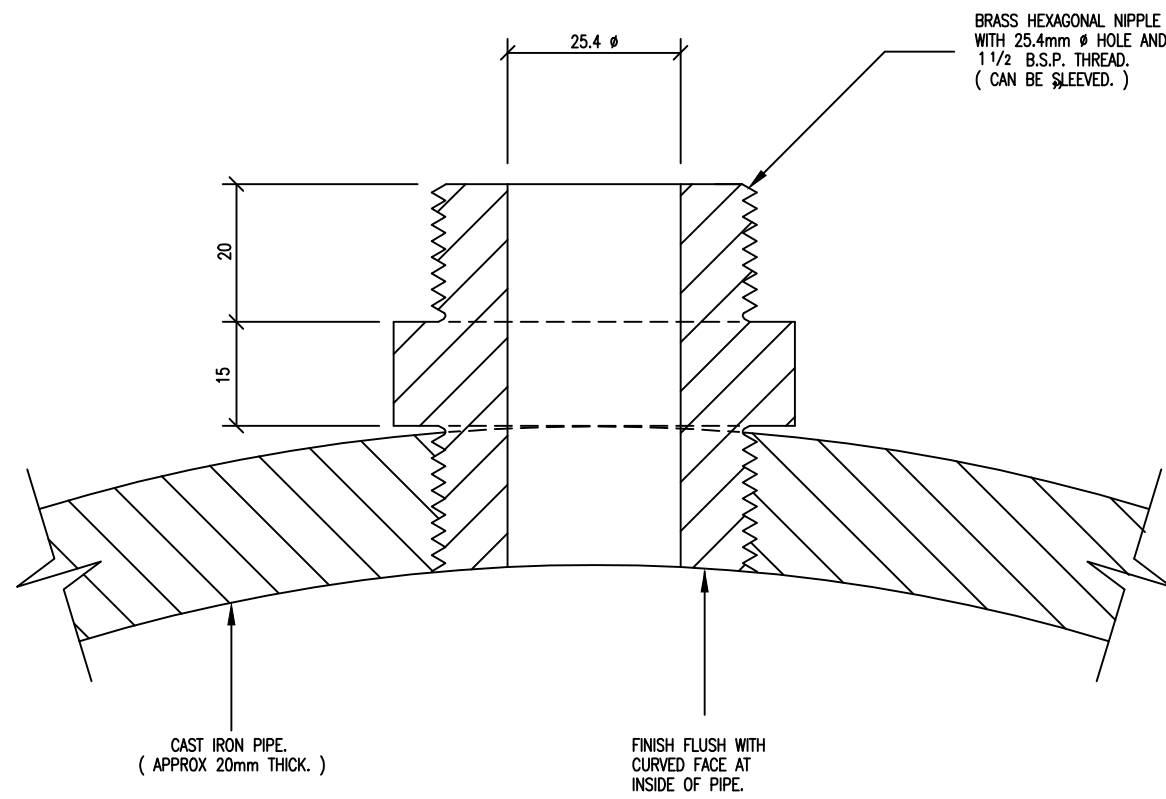

FLOW TAPPING PORT FOR CAST IRON PIPE.  
SCALE 1:1

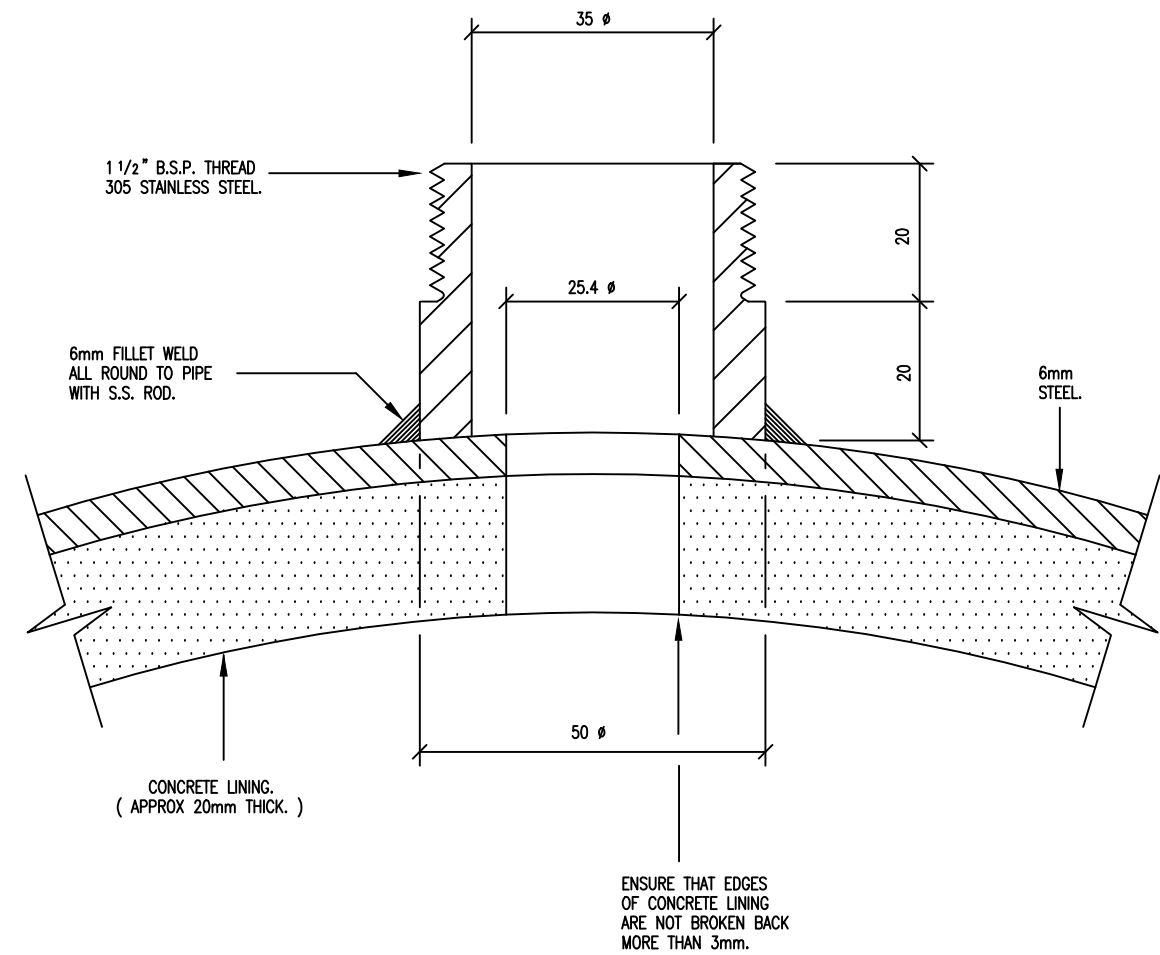

FLOW TAPPING PORT FOR CONCRETE LINED STEEL PIPE.  
SCALE 1:1

DESIGNED	H. STEWART		
DES. CHECKED			
DRAWN	L. COLLINGE	6/96	
DWG. CHECKED			
APPROVED			
ISSUE DATE	AMENDMENT	BY	APPD.
		BY	DATE

OPERATIONS MANAGER  
WATER

PLANNING MANAGER  
WATER



WATERCARE SERVICES WATER RETICULATION  
STANDARD TAPPING PORTS.  
TAPPING PORTS FOR CAST IRON AND CONCRETE LINED PIPES

CAD FILE: 2001979.031	DATE: 29:08:01
ORIGINAL SCALE A3	CONTRACT No.
1:1	
DRAWING No.	ISSUE
2001979 .031	



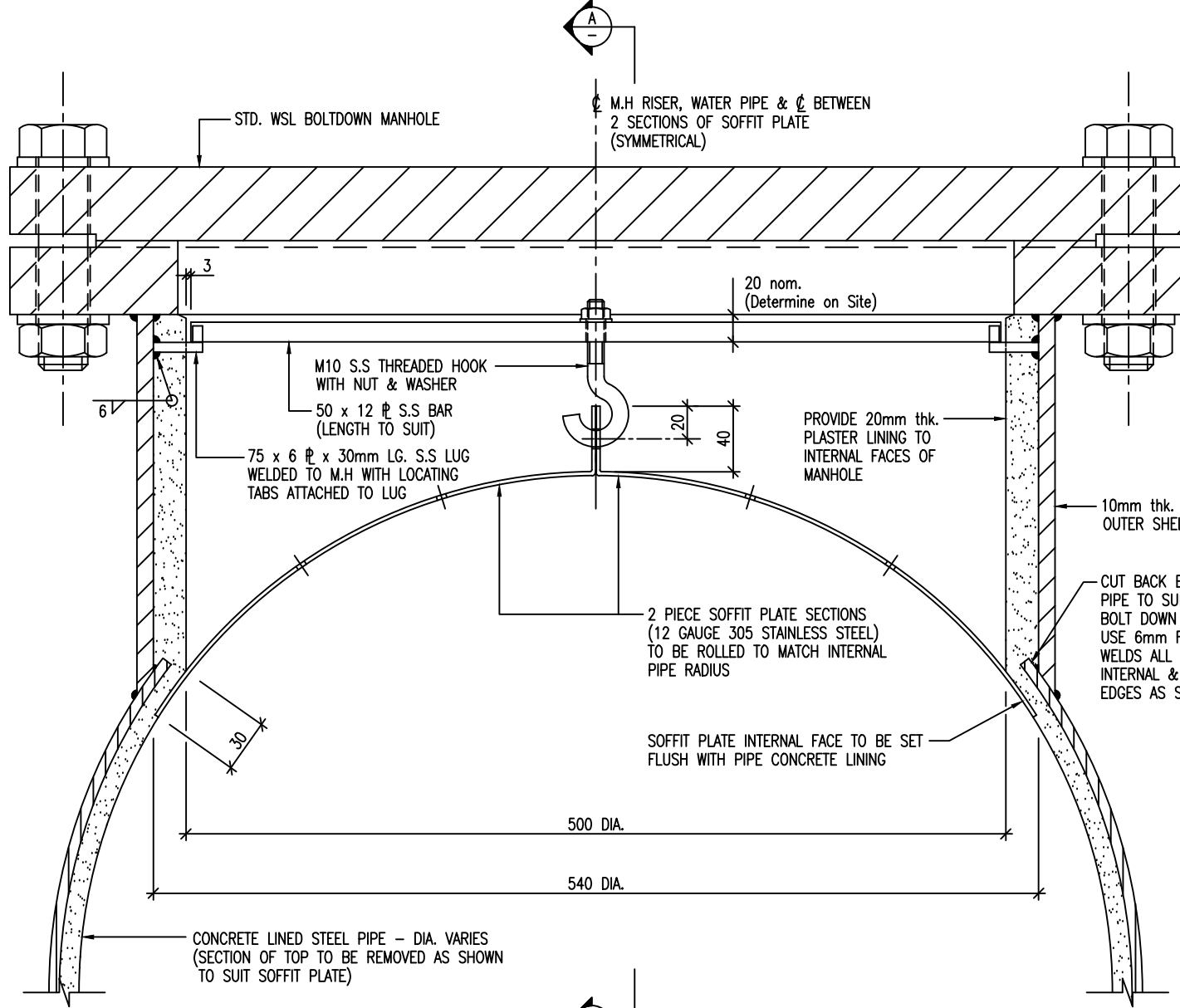

SECTIONAL ELEVATION  
SCALE 1 : 2

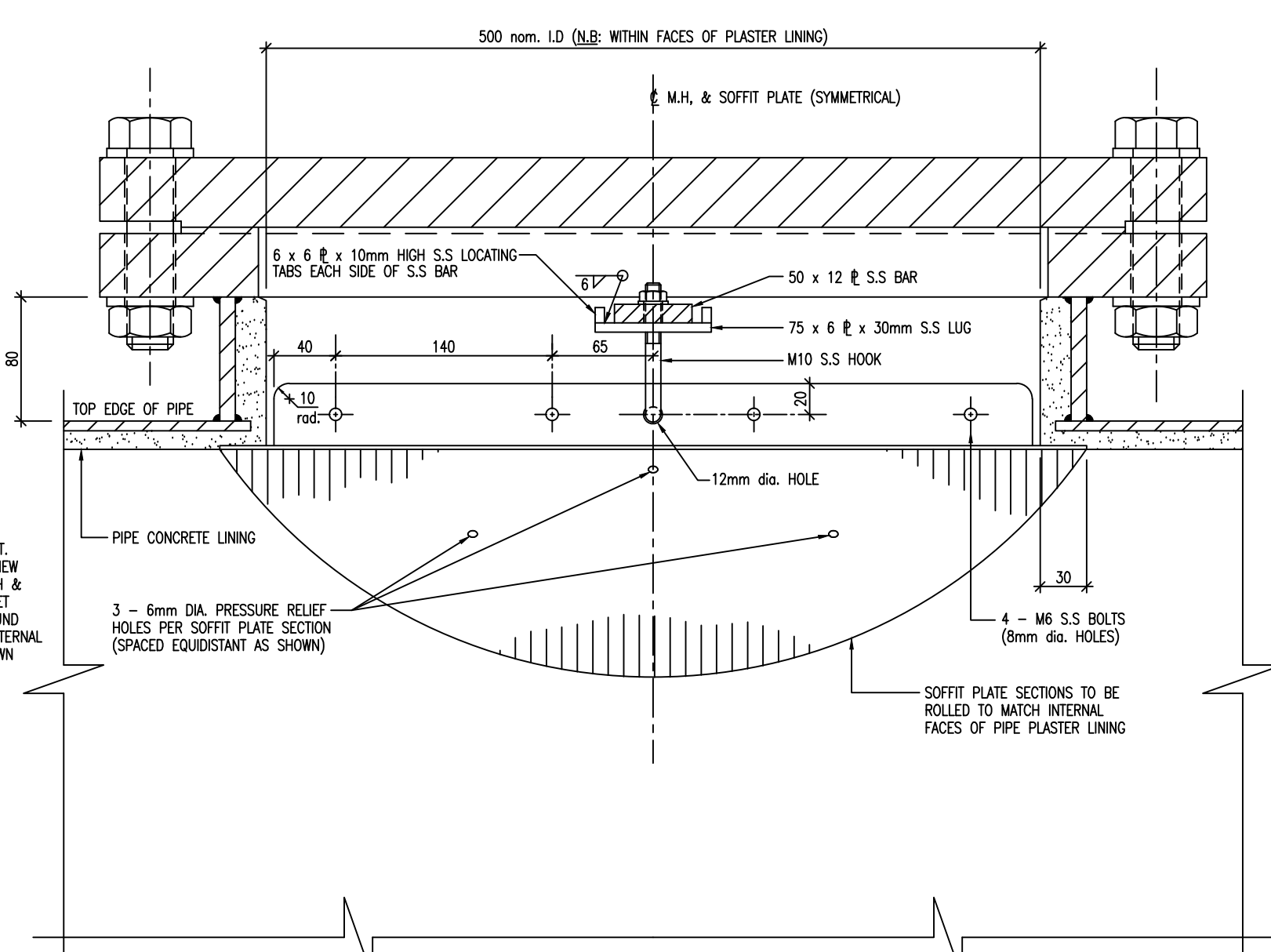

SECTION A-A  
SCALE 1 : 2

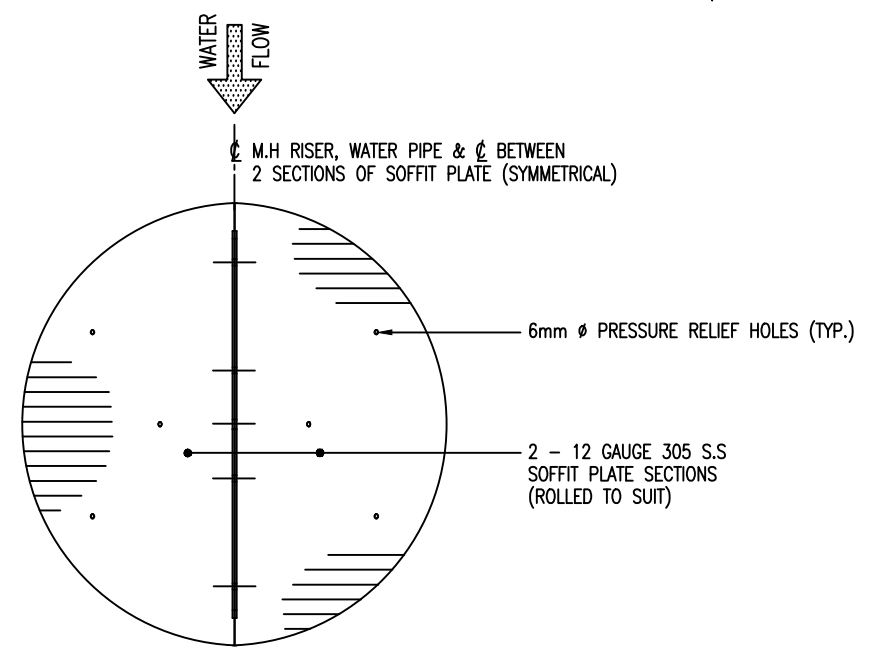

SOFFIT PLATE - PLAN VIEW  
SCALE 1 : 5

- NOTES**
1. ALL S.S. SECTIONS & PLATE TO BE GRADE 305 STAINLESS STEEL.
  2. ALL WELDS TO BE 6mm (min.) FULL STRENGTH FILLET WELDS.
  3. STD. WSL BOLT-DOWN MANHOLE TO BE SUPPLIED COMPLETE BY WSL.
  4. ALL MORTAR & PLASTER USED FOR CONCRETE LINING TO BE TO WSL STANDARDS & ANY EXIST. PLASTER DAMAGED DURING INSTALLATION TO BE REPAIRED TO ENGINEER'S SATISFACTION.

DESIGNED	H. STEWART				
DES. CHECKED					
DRAWN	M.S.	5/96			
DWG. CHECKED					
PROJECT LEADER					
RECOMMENDED					
ISSUE	DATE	AMENDMENT	BY	APPD.	BY

OPERATIONS MANAGER  
WATER

PLANNING MANAGER  
WATER



WATERCARE SERVICES WATER RETICULATION  
STANDARD MANHOLE SOFFIT PLATE FOR FLOW STREAMLINING  
DETAILS AND ELEVATION ON SOFFIT PLATE

CAD FILE 2001979.032	DATE 29:08:01
ORIGINAL SCALE A1	CONTRACT No.
AS SHOWN	
DRAWING No.	ISSUE
2001979 .032	

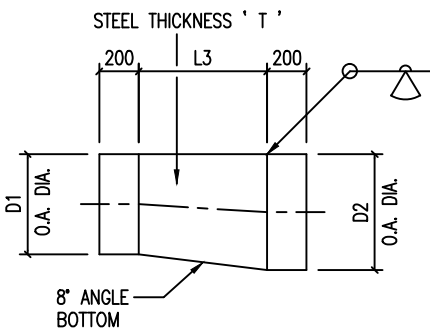

ELEVATION OF CLS  
ECCENTRIC TAPER  
NOT TO SCALE.

NOTE  
D1 & D2 ARE  
THE NOMINAL  
PIPE SIZES AS  
SHOWN IN THE  
TABLE TO THE  
RIGHT

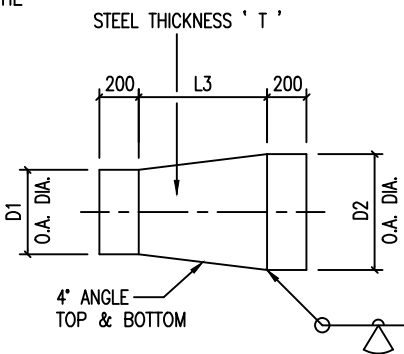

ELEVATION OF CLS  
CONCENTRIC TAPER  
NOT TO SCALE.

NOTE

THE CENTRELINE LENGTH OF THE BEND ( $L_c$ )  
CAN BE DETERMINED AS FOLLOWS:

BENDS 0° TO 30° :  $L_c = 2L_1 + D \tan(\theta/2)$   
 BENDS 31° TO 60° :  $L_c = 3L_1 + 2D \tan(\theta/4)$   
 BENDS 61° TO 90° :  $L_c = 4L_1 + 3D \tan(\theta/6)$

WHERE D = OUTSIDE DIAMETER OF PIPE.

TAPER DIMENSIONS FOR  
CLS PIPE NOMINAL  
DIAMETERS D1 & D2

D1	D2	L3	T
100	150	400	5
100	200	790	5
100	250	1180	5
150	200	380	5
150	250	770	5
150	310	1190	5
200	250	380	5
200	310	810	5
200	390	1390	6
250	310	420	5
250	390	1000	6
250	470	1580	6
310	390	580	6
310	470	1160	6
310	550	1730	6
390	470	580	6
390	550	1150	6
390	630	1720	6
470	550	570	6
470	630	1140	6
470	700	1720	6
550	630	570	6
550	700	1140	6
550	730	1340	8
630	700	570	6
630	730	770	8
630	760	1040	8
700	730	200	8
700	760	470	8
700	810	790	8
730	760	270	8
730	810	590	8
730	910	1360	8
760	810	310	8
760	910	1090	8
760	1070	2220	10

FOR PIPE SIZES GREATER  
THAN THOSE SHOWN  
SEE ENGINEER

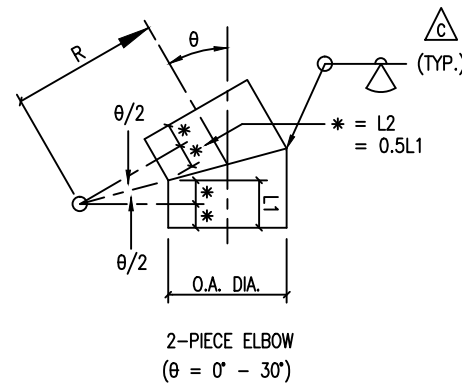

CLS PIPE BENDS  
NOT TO SCALE.

CLS PIPE BEND DIMENSIONS						
WHERE * = L2 = 0.5L1						
N.B.	BENDS 0° TO 30°		10° BEND	20° BEND	30° BEND	
	O.A. DIA.	L1	L2	R	R	R
100	121	150	75	918	486	340
150	178	150	75	946	514	369
200	232	150	75	973	541	396
250	286	150	75	1000	568	423
310	345	150	75	1030	598	452
390	426	150	75	1070	638	493
470	507	150	75	1111	679	533
550	587	150	75	1151	719	573
630	667	200	100	1477	901	707
700	747	200	100	1517	941	747
730	775	200	100	1531	955	761
760	813	200	100	1550	974	780
810	857	250	125	1857	1137	895
910	965	250	125	1911	1191	949
1070	1124	300	150	2277	1413	1122
1300	1365	350	175	2683	1675	1336
1500	1562	400	200	3067	1915	1527
1700	1762	450	225	3453	2157	1721
1900	1965	500	250	3840	2400	1915

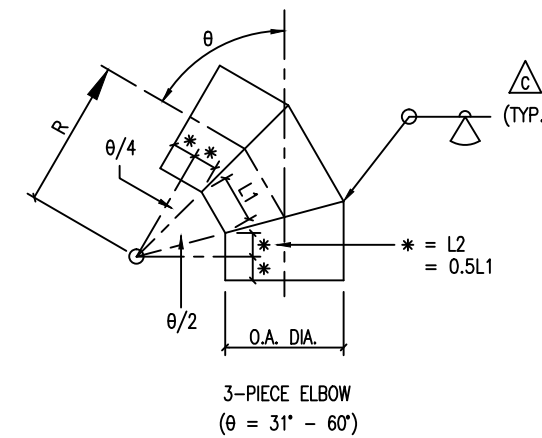

CLS PIPE BENDS  
NOT TO SCALE.

CLS PIPE BEND DIMENSIONS						
WHERE * = L2 = 0.5L1						
N.B.	BENDS 31° TO 60°		45° BEND	50° BEND	60° BEND	
	O.A. DIA.	L1	L2	R	R	R
100	121	150	75	438	399	340
150	178	150	75	466	427	369
200	232	150	75	493	454	396
250	286	150	75	520	481	423
310	345	150	75	550	511	452
390	426	150	75	590	551	493
470	507	150	75	631	592	533
550	587	150	75	671	632	573
630	667	200	100	836	785	707
700	747	200	100	876	825	747
730	775	200	100	890	839	761
760	813	200	100	909	858	780
810	857	250	125	1057	992	895
910	965	250	125	1111	1046	949
1070	1124	300	150	1316	1239	1122
1300	1365	350	175	1562	1472	1336
1500	1562	400	200	1787	1683	1527
1700	1762	450	225	2012	1896	1721
1900	1965	500	250	2239	2110	1915

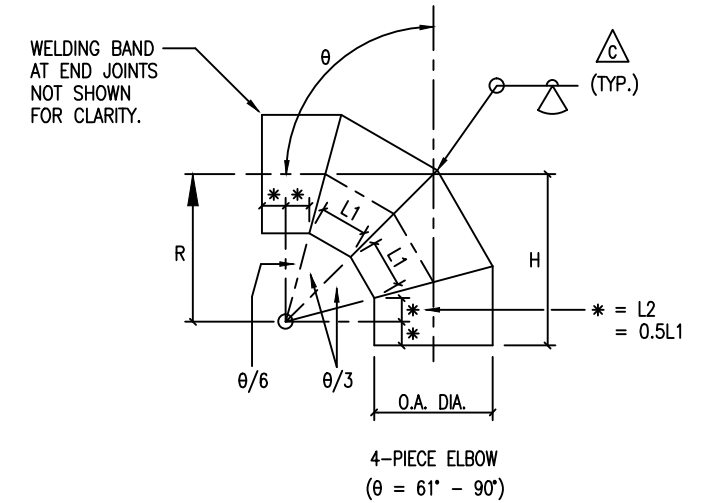

CLS PIPE BENDS  
NOT TO SCALE.

CLS PIPE BEND DIMENSIONS										
WHERE * = L2 = 0.5L1										
N.B.	BENDS 61° TO 90°		70° BEND		80° BEND		90° BEND		R	H
	O.A. DIA.	L1	L2	R	H	R	H	R		
100	121	150	75	424	499	377	452	340	415	
150	178	150	75	452	527	406	481	369	444	
200	232	150	75	479	554	433	508	396	471	
250	286	150	75	506	581	460	535	423	498	
310	345	150	75	536	611	489	564	452	527	
390	426	150	75	576	651	530	605	493	568	
470	507	150	75	617	692	570	645	533	608	
550	587	150	75	657	732	617	685	573	648	
630	667	200	100	818	918	755	855	707	807	
700	747	200	100	858	958	795	895	747	847	
730	775	200	100	872	972	809	909	761	861	
760	813	200	100	891	991	828	928	780	880	
810	857	250	125	1034	1159	956	1081	895	1020	
910	965	250	125	1088	1213	1010	1135	949	1074	
1070	1124	300	150	1290	1440	1195	1345	1122	1272	
1300	1365	350	175	1530	1705	1421	1596	1336	1511	
1500	1562	400	200	1750	1950	1625	1825	1527	1727	
1700	1762	450	225	1971	2196	1830	2055	1721	1946	
1900	1965	500	250	2193	2443	2037	2287	1915	2165	

ISSUE	DATE	AMENDMENT	BY	APPD.	DESIGNED	T.C. / L.C.	5-05
C	9-14	WELDING SYMBOLS FOR SEALING RUNS	I.M.	B.P.	DWG. CHECKED	I.M.	5-05
B	9-11	NOTE ADDED	L.C.	T.C.	T.C.	T.C.	5-05
A	3-07	TAPER DETAILS MOVED FROM 2001979.058	I.M.	T.C.	PROJECT LEADER	T.C.	5-05

T. HAWKE	OPERATIONS
A. STEWART	INFRASTRUCTURE

COPYRIGHT  
This drawing, the design and concept, remain the exclusive property of Watercare Services Limited and may not be used without approval  
Copyright reserved.

WATER RETICULATION STANDARD  
CLS PIPELINE FITTINGS  
TAPERS AND BEND SETOUT DIMENSIONS

CAD FILE 2001979.060B	DATE 23-9-14
ORIGINAL SCALE A1	CONTRACT No.
AS SHOWN	
DRAWING No.	ISSUE
2001979 060	C

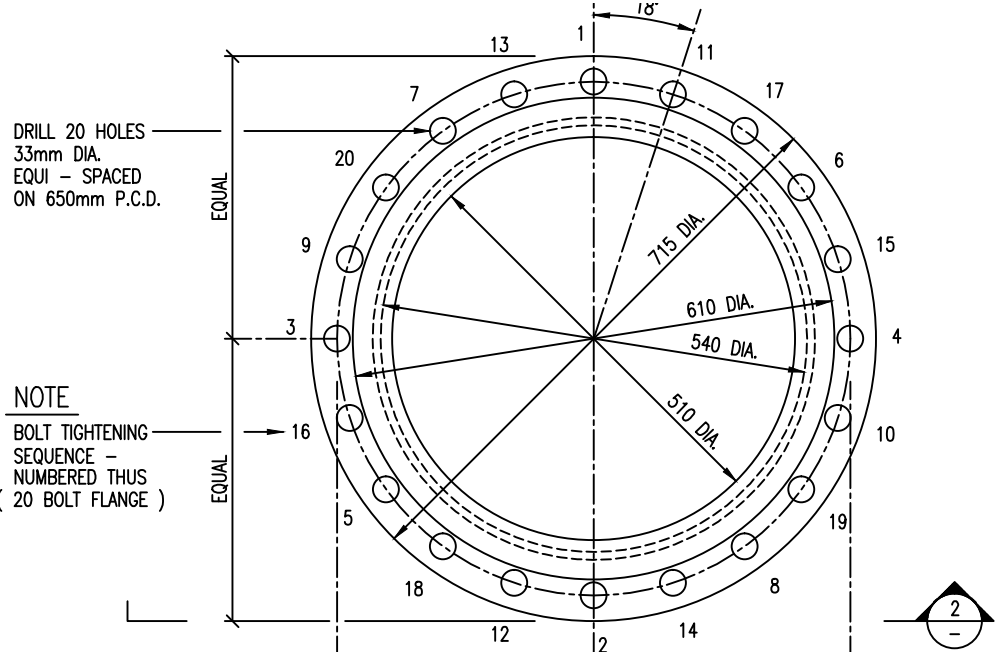

NOTE  
BOLT TIGHTENING SEQUENCE - NUMBERED THUS ( 20 BOLT FLANGE )

PLAN 1

SCALE: 1:5

NOTES FOR BOLT DOWN ACCESS MANHOLE

- MILD STEEL USED SHALL BE IN ACCORDANCE WITH NZS / BS 1504 : 1976
- ALL WELDING SHALL BE IN ACCORDANCE WITH THE FOLLOWING STANDARDS :-  
- NZS / BS 2971 : 1991  
- NZS 4711 : 1984
- MACHINING OF FLANGES SHALL BE TO BS 4504 SECTION 3.1 : 1989  
GASKET FACES SHALL HAVE A CONTINUOUS SPIRAL GROOVE GENERATED BY A 1/8" RADIUS ROUND-NOSE TOOL AT A FEED OF APPROXIMATELY 3/64" PER REVOLUTION. MACHINED FACES TO BE COVERED WITH RUST VETO AFTER MACHINING.
- BOLTS SHALL BE TIGHTENED IN CORRECT SEQUENCE. REFER PLAN 1
- BOLTS SHALL BE HOT-DIP GALVANISED & TORQUED TO 65% YIELD OF 671Nm WITH A TORQUE INCREMENT OF 390 Nm.
- INTERNAL LINING SHALL BE AS SHOWN ON DETAIL A  
EMACO S88C-THIXOTROPIC - TYPE SHRINKAGE CONTROLLED REPAIR MORTAR SHALL BE USED
- FOLLOWING INSTALLATION MANHOLE SHALL BE EXTERNALLY PROTECTED IN ACCORDANCE WITH WATERCARE'S PAINTING SPECIFICATION.

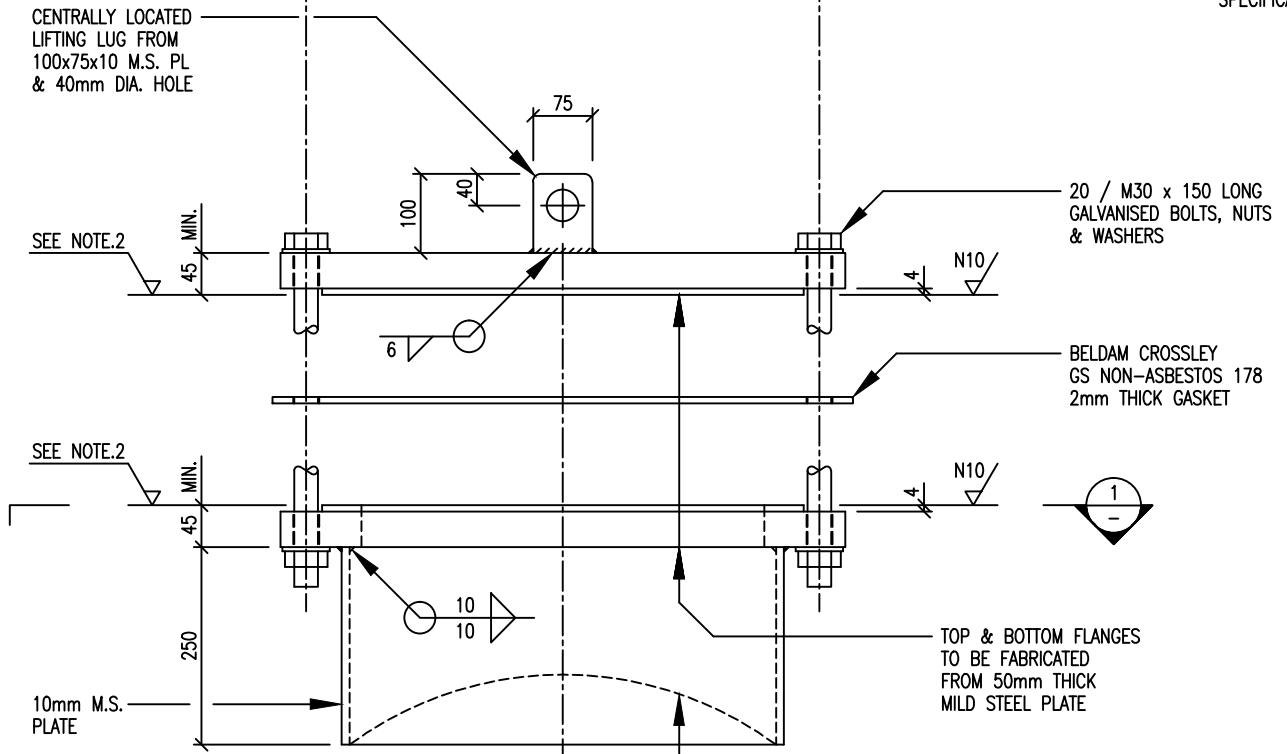

ELEVATION 2

SCALE: 1:5

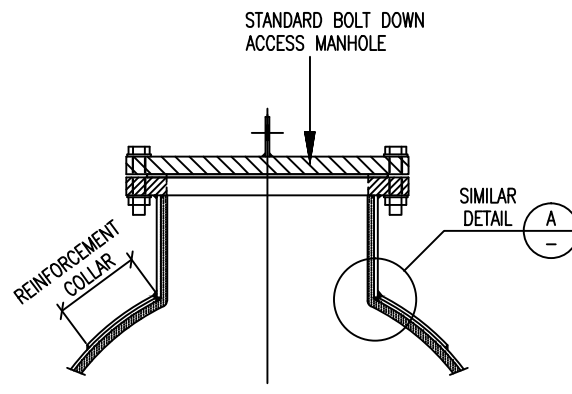

SECTION 3

SCALE: 1:10

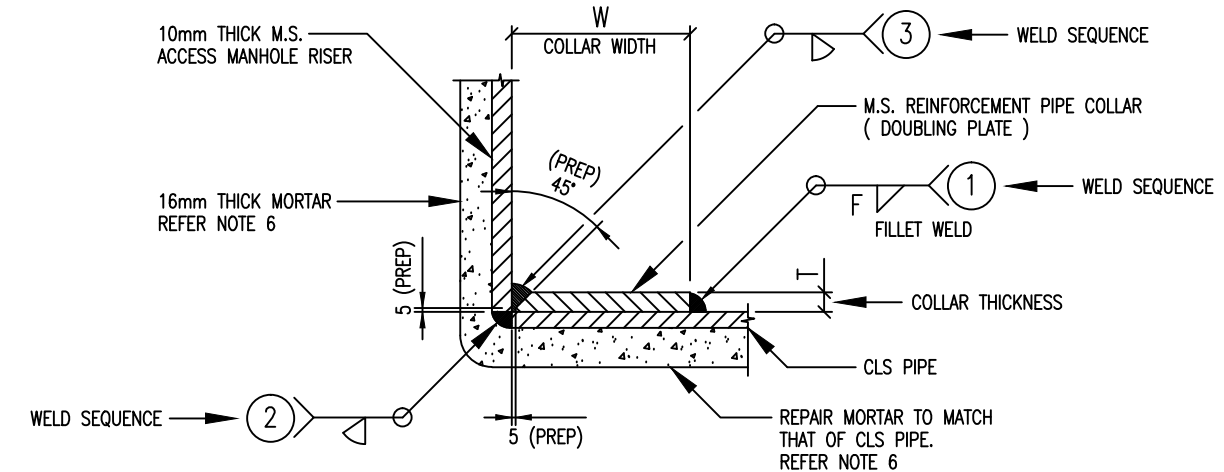

DETAIL A

NOT TO SCALE

TYPICAL PIPE COLLAR & INTERNAL LINING DETAIL

TABLE FOR M.S. PLATE COLLAR SIZES						
MANHOLE RISER		MAIN PIPE		20 BAR COLLAR		WELD
O.D. mm	t mm	O.D. mm	t mm	W mm	T mm	F mm
560	10	667	6.33	240	8	6
"	"	747	6.33	260	8	6
"	"	775	7.94	210	8	8
"	"	813	7.94	220	8	8
"	"	857	7.94	240	8	8
"	"	965	7.94	230	10	8
"	"	1124	9.53	270	10	10
"	"	1365	9.53	240	16	10
"	"	1562	9.53	240	20	10
"	"	1762	11.11	270	20	10
"	"	1965	11.11	250	25	10

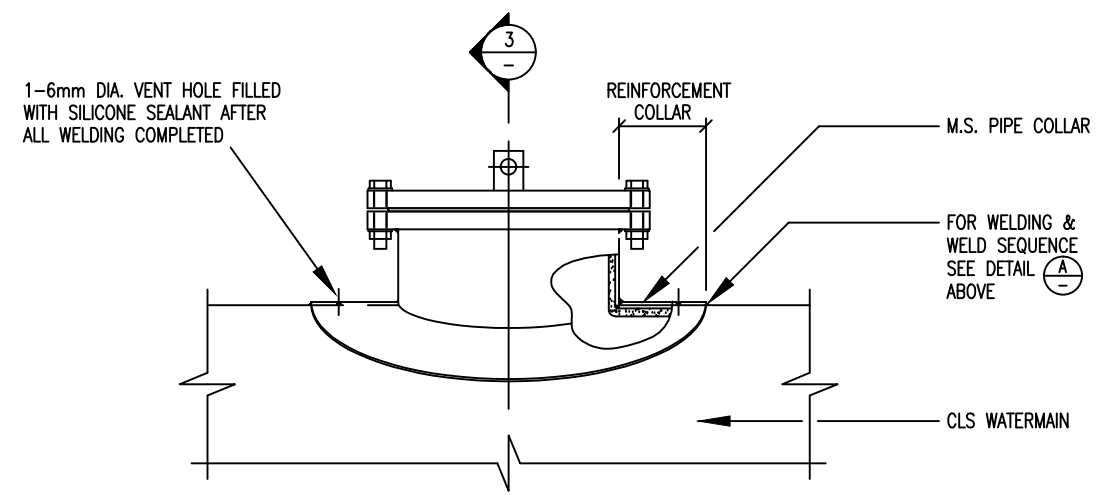

PIPE COLLAR DETAIL

SCALE 1:10

BOLT DOWN ACCESS MANHOLE

ISSUE	DATE	AMENDMENT	BY	APPD.	DATE
-	9:06	FOR CONSTRUCTION	L.C.	T.C.	
1	8:06	FOR CLIENT APPROVAL	L.C.	T.C.	

DESIGNED	J.P.	11/06
DES. CHECKED	T.C.	11/06
DRAWN	L. A. COLLINGE.	08:06
DWG. CHECKED		
PROJECT LEADER		

COPYRIGHT This drawing, the design and concept, remain the exclusive property of Watercare Services Limited and may not be used without approval Copyright reserved.

WATERCARE SERVICES WATER RETICULATION  
STANDARD PIPELINES  
ACCESS MANHOLE - BOLTED DOWN TYPE

CAD FILE	2001979.074	DATE	4-9-06
ORIGINAL SCALE	A1	CONTRACT No.	-
AS SHOWN			
DRAWING No.	2001979	ISSUE	-
.074			

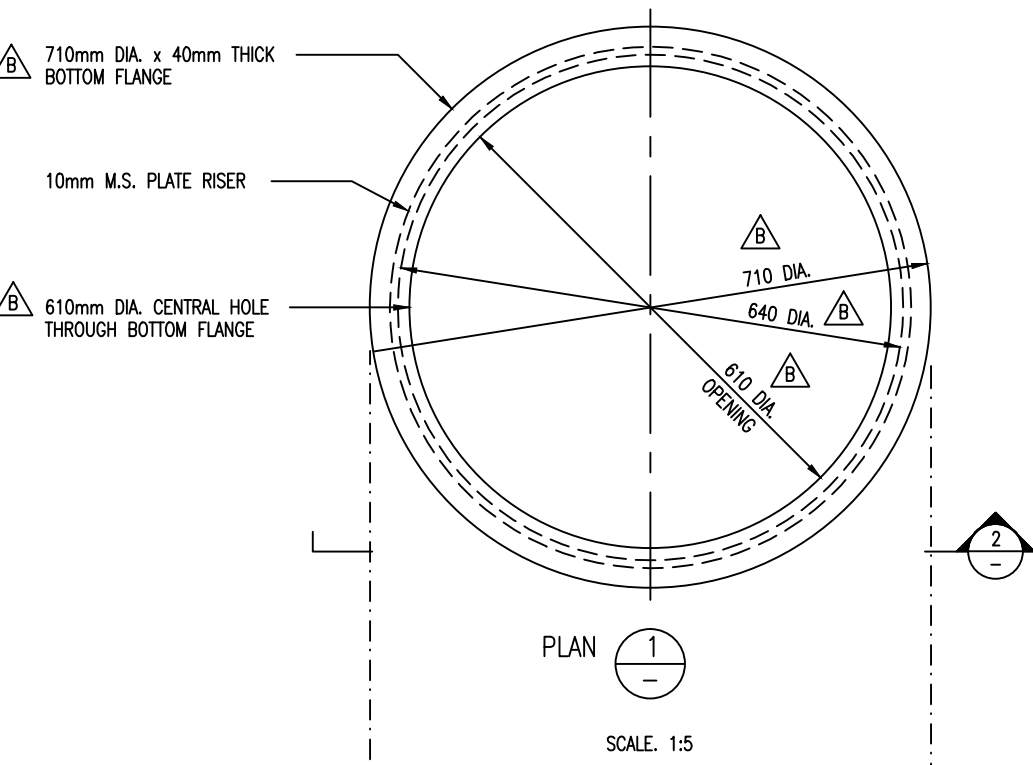

**NOTES FOR WELD DOWN ACCESS MANHOLE**

- MILD STEEL USED SHALL BE IN ACCORDANCE WITH BS EN 10213:2007
- ALL WELDING SHALL BE IN ACCORDANCE WITH THE FOLLOWING STANDARDS :-  
- BS 2971:1991  
- AS/NZS 2980:2007
- INTERNAL LINING SHALL BE AS SHOWN ON DETAIL EMACO S88C-THIXOTROPIC TYPE SHRINKAGE CONTROLLED REPAIR MORTAR SHALL BE USED.
- FOLLOWING INSTALLATION MANHOLE SHALL BE EXTERNALLY PROTECTED IN ACCORDANCE WITH WATERCARE'S SPECIFICATION.

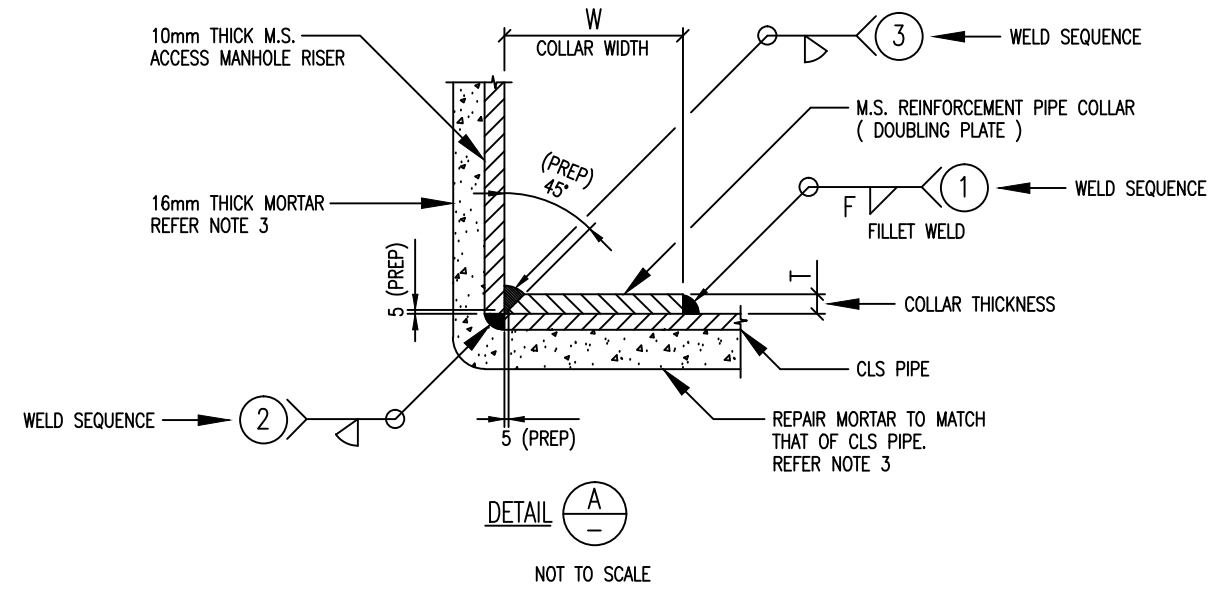

**TYPICAL PIPE COLLAR & INTERNAL LINING DETAIL**

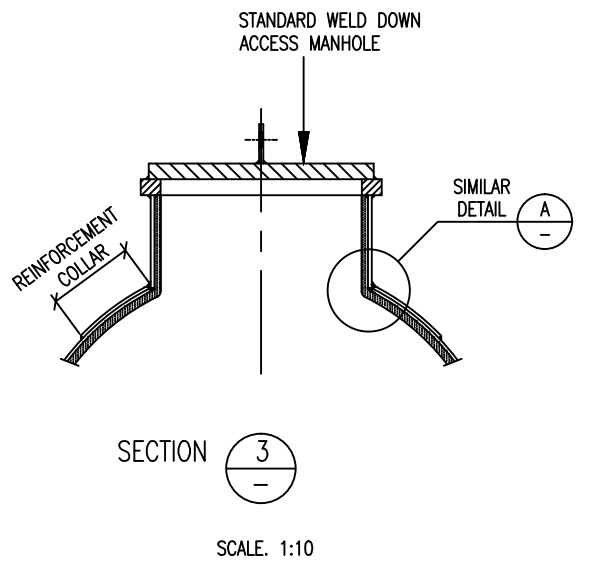
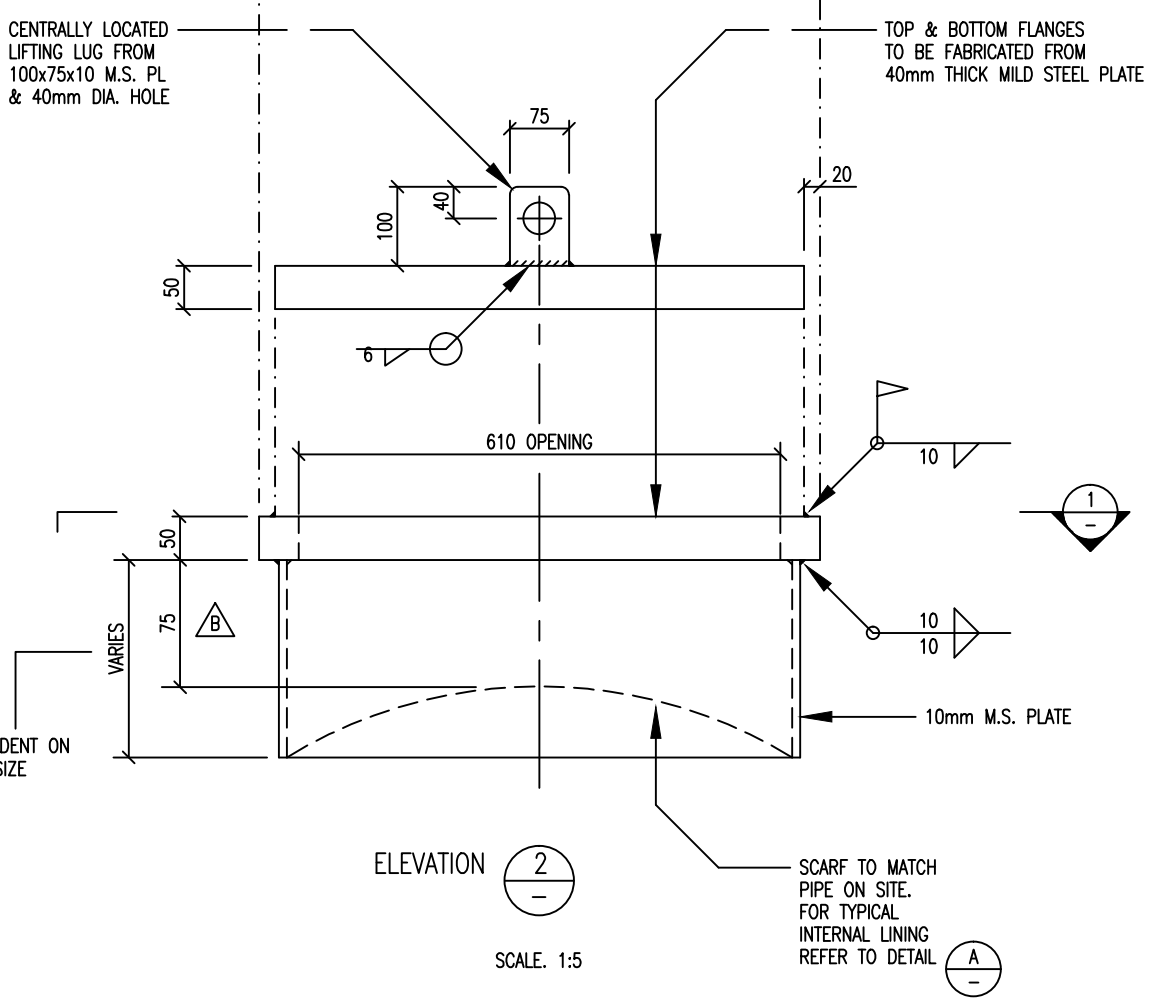

**TABLE FOR M.S. PLATE COLLAR SIZES**

MAIN PIPE		MANHOLE RISER		16 BAR COLLAR		WELD	20 BAR COLLAR		WELD
O.D. mm	t mm	O.D. mm	t mm	W mm	T mm	F mm	W mm	T mm	F mm
747	6.33	660	10	220	5	5	*		
775	7.94	"	"	220	5	5	*		
813	7.94	"	"	220	5	5	*		
857	7.94	"	"	220	5	5	225	8	8
965	7.94	"	"	220	5	5	220	10	8
1124	9.53	"	"	220	5	5	220	10	10
1365	9.53	"	"	220	8	8	220	12	10
1562	9.53	"	"	270	8	8	290	12	10
1762	11.11	"	"	230	10	10	240	16	10
1965	11.11	"	"	250	12	10	240	20	10

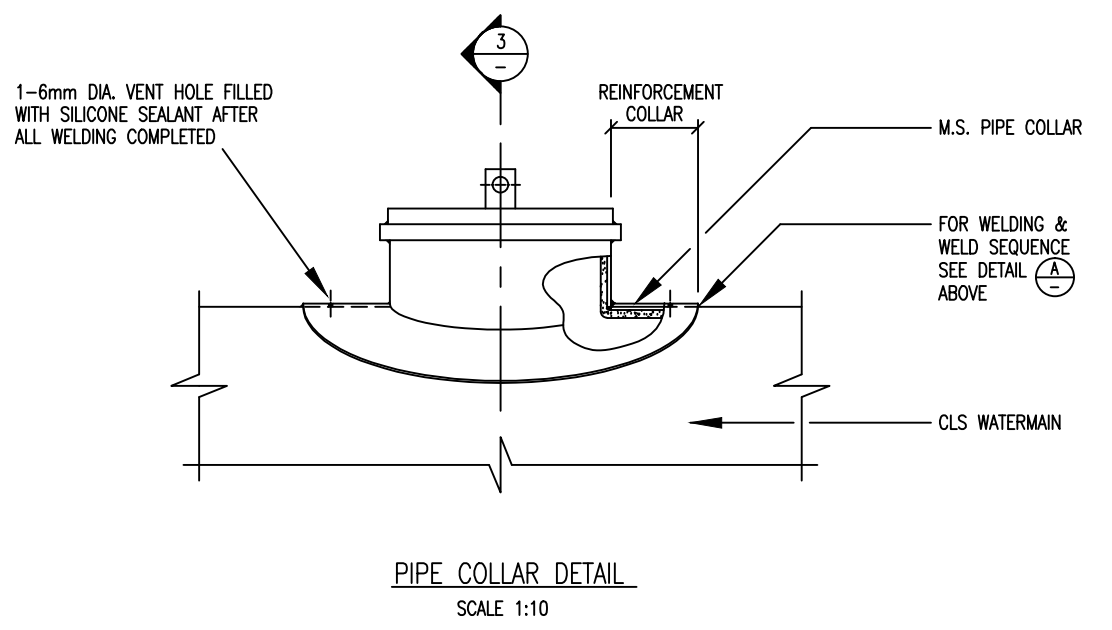

**WELD DOWN ACCESS MANHOLE**

**SECTION 3**

**PIPE COLLAR DETAIL**

ISSUE	DATE	AMENDMENT	BY	APPD.	BY	DATE	INFRASTRUCTURE
B	02-13	MANHOLE DIMENSIONS CHANGED	I.M.	B.P.			
A	12-07	NOTE REFERENCES CORRECTED	I.M.	T.C.			
-	9:06	FOR CONSTRUCTION	L.C.	T.C.			
1	8:06	FOR CLIENT APPROVAL	L.C.	T.C.			

DESIGNED	J.P.	11/06
DES. CHECKED	T.C.	11/06
DRAWN	L. A. COLLINGE.	08/06
DWG. CHECKED		
PROJECT LEADER		



WATER SUPPLY STANDARD  
ACCESS MANHOLE FOR PIPES ≥ 700 NOM. DIA.  
WELD DOWN TYPE

CAD FILE 2001979.075B	DATE 26-03-13
ORIGINAL SCALE A1	CONTRACT No.
AS SHOWN	-
DRAWING No.	ISSUE
2001979 .075	B

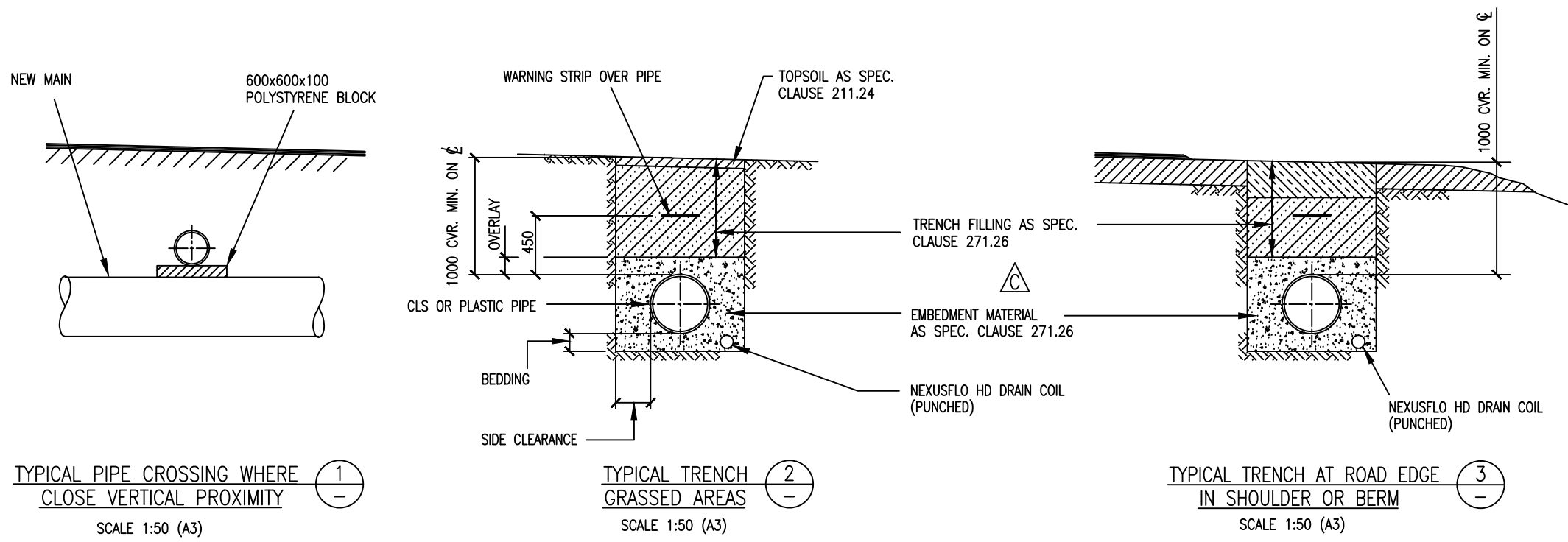

**NOTES**

1. MINIMUM TRENCH AND EMBEDMENT DIMENSIONS

PIPE OD (mm)	EMBEDMENT MATERIAL UNDER PIPE (mm)	SIDE CLEARANCE FROM TRENCH (mm) (SEE SPECIFICATION PARTICULAR CLAUSES)	EMBEDMENT MATERIAL OVER PIPE (mm)	NEXUSFLO HD DRAIN COIL SIZE (mm)
150 TO 300	100	150	150	110
310 TO 450	100	200	150	110
460 TO 900	150	300	150	110
910 TO 1500	150	350	200	160

2. WARNING PLASTIC STRIP, MIN. 100mm WIDE OVER PIPE, BLACK WORDING:

- a) FOR WATERMAIN: COLOURED BLUE WITH REPEATING WORDING "CAUTION - WATERMAIN BELOW"
- b) FOR SEWER: COLOURED GREEN WITH REPEATING WORDING "CAUTION - SEWER BELOW"

3. WARNING STRIP OVER PLASTIC PIPES IS TO BE DETECTABLE METALLIC TYPE

4. WHERE TRENCH WIDENING IS REQUIRED FOR PIPE WELDING ACCESS, THE PROFILE OF SURFACE REINSTATEMENT SHALL BE EQUIVALENT TO ADJACENT TRENCH REINSTATEMENT.

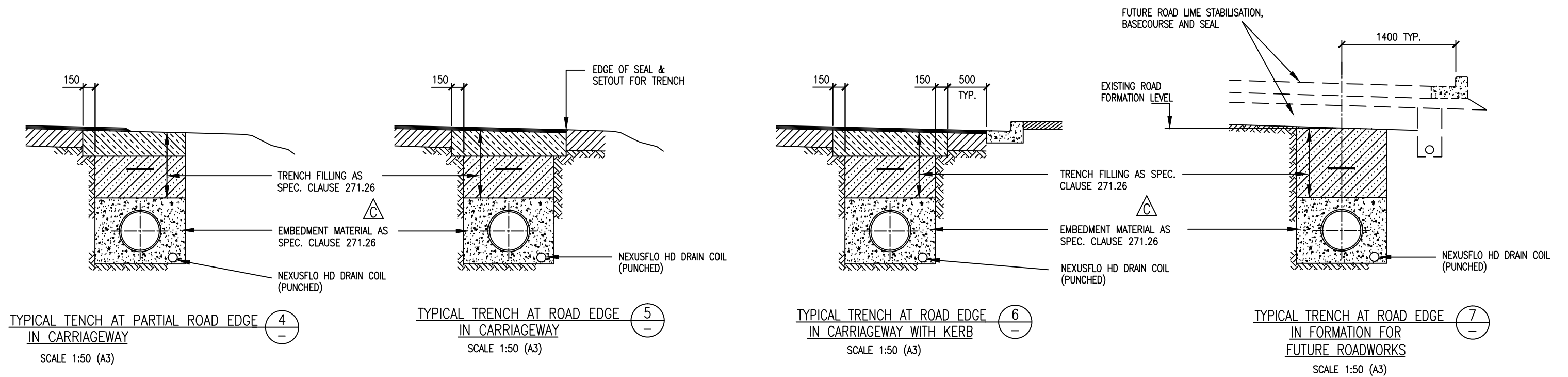

ISSUE	DATE	AMENDMENT	BY	APPD.	DESIGNED	J.P.	9-09	DES. CHECKED	T.C.	9-09	DRAWN	I.M.	9-09	DWG. CHECKED	L.C.	9-09	PROJECT LEADER	J.P.	A.M. APPROVED	J.P.	BY	APPD.	BY	DATE	
C	10-11	CLAUSE REFERENCES AMENDED	I.M.	T.C.																					
B	08-11	PLAN TITLE AMENDED	I.M.	T.C.																					
A	9-09	OVERALL PLAN REVISED	I.M.	J.P.																					
-	12:07	FOR CONSTRUCTION - REPLACES DWG 2001979.080	L.C.	J.P.																					

T. HAWKE  
OPERATIONS

A. STEWART  
ASSET MANAGEMENT



RETICULATION STANDARD  
PIPE TRENCHES  
TYPICAL BEDDING, BACKFILL & REINSTATEMENT DETAILS

CAD FILE 2001979.092C	DATE 27-10-11
ORIGINAL SCALE A3	CONTRACT No.
AS SHOWN	-
DRAWING No.	ISSUE
2001979 .092	C